



*Viewing overlapped contents in Augmented Reality*

# Regenerating Regeneration: augmented reality and new models of minor architectural heritage reuse

*Adolfo F. L. Baratta<sup>1</sup>, Fabrizio Finucci<sup>1</sup>, Antonio Magarò<sup>1</sup>*

*<sup>1</sup>Department of Architecture, Roma Tre University*

## ABSTRACT

---

The paper presents the first results of an interdisciplinary research conducted by the Department of Architecture of Roma Tre University aimed at developing guidelines for enhancement of minor architectural heritage, urban and suburban. The research evaluates the creation of a widespread museum that exploit cultural dissemination technologies in augmented reality. The economic crisis, not yet overcome, leads to rethink urban development and heritage conservation, reorienting design towards techniques and practices of reuse. These strategies represent one of the most effective ways to enhance and protect the minor architectural heritage, often protagonist of degradation and abandonment. It seems necessary that the architectural heritage protection has been articulated through contemporaneity, adapting itself to the age of Information Communication Technology. In addition to the architectural heritage, strictly intended as a monument, Italy has a complex system of goods well explained, in the broadest sense, as "minor architectural heritage". This approach makes possible to identify the Italian Historical Cities as a new category of widespread heritage to be protected. Consequently, it emerges the need to put aside the discretization in punctual assets, approaching an entire system of architectural goods, characterized by a high degree of complexity. Valuing the latter in a sustainable way also passes through new technologies as augmented reality.

---

## KEYWORDS

*augmented reality, architectural heritage reuse*

## 1. INTRODUCTION

The most common strategies of conservation and restoration are mainly directed towards the architectural heritage that can be identified as a monument. However, this sentiment is widely outweighed both by the legislator and by scientific research. In 1967, the so-called Franceschini Commission, named as his President, Francesco Franceschini (Colavitti, 2018), indicated the need to study the "material witness of civilization value" (ICAR, 2000). In 1972, the Paris Convention generalized the ownership of these goods spread throughout the territory, regardless of the geographical location. Over the years, an interpretative breadth has emerged from these fundamental principles: it makes obsolete the notion of "minor" architectural heritage. In fact, the meaning of "major" or "minor" is closely linked to the territory of influence of the goods, because its enhancement can determine highly-localized economic repercussions.

The Franceschini Commission itself identified the Historical Cities as a new category of architectural



**Figure 1.**  
*Diffusion of the Historical  
Cities in Italy (ICCD, 2018).*

heritage. His proceedings reiterate that monumental value is not intrinsic in the single building, but also consists of relationships with the context whose stratification is not only physical but also historical. In Italy, the Historical Cities are 22.621, according to the ICCD, "Istituto Centrale di Catalogazione e Documentazione" of the MiBAC (Ministero dei Beni e delle Attività Culturali) (ICCD, 2018). It needs to add the data of the ISTAT, Italian National Institute of Statistics which counts 7.800 Historical Cities out of 8.000 municipalities, as well as 15.000 smaller nuclei (Frate, 2010).

Therefore, the monumental architectural heritage has the same importance as the so-called minor one, of which the Italian urbanized and rural territory is composed.

## 2. METHODS AND TOOLS: PERCEPTION MODELS AND NEW APPLICATION FIELDS

Before evaluating how the research intends to join new models of reality perception and cultural information fruition, to enhance the minor architectural heritage, it is essential to give some definitions and retrace the evolution over time of the technologies described in this paper.

In the first half of the nineties, the Industrial Engineering Department of the University of Toronto provides the first definition of AR: "AR can be regarded in terms of continuum relating purely virtual environments to purely real environments" (Milgram et al. 1994). This in embryo definition puts into relations purely virtual environments, produced by computers (already capable to generate three-dimensional graphics) and purely real environments.

Today, it could give a less vague definition of this technology. AR is a technology for rendering digitized information characterized by the superposition to real elements of additional contents such as virtual elements, multimedia, geolocated data, etc. Those augmented contents can be enjoyed by using physical interfaces, whose hardware ranges from the most invasive systems (helmets or viewers, defined as "see-

through AR displays") to the less invasive tool such as personal devices, as smartphones and tablets. The quality of reproduction of real contents integrated with virtual ones is very important for the realization of immersive experiential scenarios. This is possible thanks to the computing power available today also on relatively cheap devices. The dissemination of AR contents has allowed technology transfer from ICT to the protection and enhancement of cultural heritage, transforming simple unidirectional use into an engaging experience, especially in its outdoor uses. In this latter case, technology transfer is immediate, especially if it considers the dissemination of cultural contents related to the understanding of "how it was compared to what it is". In 2005, the Doshysha University in Kyoto presented one of the first outdoor application with an eloquent name: "time machine navigation system". It proposed the historical geo-referenced reconstruction of the Kyoto city center. Using the camera and the screen of a mobile phone, it could see, in AR, how the urban and architectural shape had changed. It is evident that at the base of this application there was an indispensable research work of historical and philological reconstruction (Sukigara, 2005).

Less than a decade later, the technology evolves as shown by the 2013 visual project organized by the Inter Communication Center in Tokyo, entitled "Alice's adventures in AR": within an extensive urban path, two artists, Suzuki Shiori and Nanjo Saho exhibit works, which are transformed from static into dynamics. The project, designed for children, is used in a transgenerational way. In the Old Continent, the potential of this technology translates into a series of projects funded by the European Union. One of these still exploits viewers and dedicated hardware as the so-called Head-Mounted Displays (HMD) a sort of binocular viewers equipped with a camera and connected wireless to a computer able to superimpose the real input and the virtual content, giving the user an increased output. This project, called EPOCH, returned an augmented reconstruction of the ruined nymphaeum of the Agora of Salagassos in Turkey (Nicolucci, 2005).

Since 2010, even in Italy there has been widespread

attention to this new technology aimed at cultural dissemination. In May 2011, MiBAC presented an application for the enhancement of the Imperial Forums archaeological area in Rome. This application, called "MiBAC Voyager", is part of a larger project aimed at exploiting a specific AR browser called "Layar" (Ettorre, 2010). Since that moment the experiences multiply, almost always on a public initiative. In 2010, is the case of "Tuscany+" aimed at enhancing the major cultural cities such as Florence and Pisa. One year later, in 2011, "iTTP" for urban mobile tourism in Turin and the Province, was launched by the Consortium Convention & Visitors Bureau with mixed public and private capital. The experiences involve the whole peninsula: "PugliaReality+" (2011) of the Puglia Region, "TrovaCultura" of the Lombardy Region (2012), "ARMuseo" of the Capodimonte Museum in Naples (2013) and the app related to the great exhibitions (Bonacini, 2014).

## 2.1 INNOVATIVE PERCEPTION MODELS

---

The AR applications have a very simple flow, regardless of the complication caused by the multifunctionality due to the exploitation of the accessories of the devices or their calculation powers.

In the developing and using AR contents, three distinct phases can be distinguished:

- **Recognition:** to superimpose virtual contents to the real ones, it is very important that the device univocally recognizes the latter. Therefore, it is necessary to use specific objects that can vary from the art paintings to the buildings. In some applications it is necessary to associate the object with a marker, that is a graphic code that makes it uniquely distinguishable. Another way to operate the recognition is the exploitation of GPS coordinates.
- **Tracing or Mapping:** this phase occurs when the recognition is made, in which the encoding of the environment is recognized through using

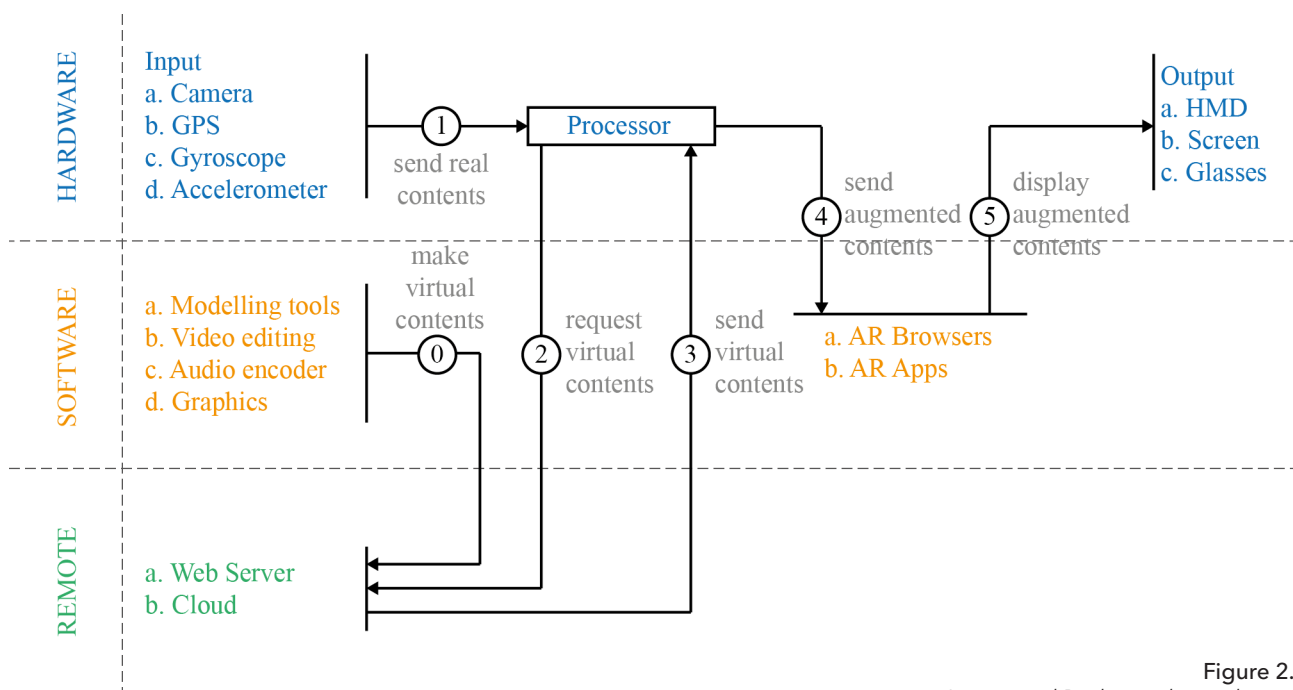

Figure 2.  
Augmented Reality working scheme.

sensors present in the device or also through the on-screen display.

- **Overlap and Alignment:** at this point the device operates a render of the real scene mixed with the virtual addition. For the experience to be suggestive, it is necessary that the virtual object integrates with the real scene showing its three-dimensionality, for example by rotating the device. Therefore, this last phase provides an alignment that makes the virtual object integrated with the environment using a common reference system. Everything is entrusted to software that generally uses graphics libraries.

In case of outdoor applications, the GPS component, nowadays present also in low-cost smartphones, and the accelerometer, a sensor with a very low cost, indispensable in any device, are exploited

because they allow the orientation of the display. The GPS is used to place the user in space, through its coordinates. Through this geolocation, it is possible to identify the mutual position of a device even in the real environment, using a digital compass. Finally, the accelerometer determines the position of both the image capture device and the display which must provide for the increased contents. This process belongs, now, to everyone's daily experience, for example, taking a simple photo with the smartphone. It is the key that allows the perfect integration between real and virtual, since the movement of the device corresponds to a change in solidarity of the display of real and virtual content. The landmarks also in the surrounding environment have been geo-referenced and, therefore, they are uniquely identified by the device, which takes care to superimpose the virtual contents. The latter can be of any kind, from the three-dimensional reconstruction, partial or total of

buildings, to external media information related to heritage, such as archival documents, audio-guides, etc.

The transition from a dedicated device, such as the HMD, to a commonly used multipurpose device, as a smartphone or a tablet, has contributed to the diffusion of this technologies. Despite this, there is still a kind of resistance in the use of AR, probably because such devices, unlike HMD, do not allow an immersive experience. Another problem in the diffusion of AR is linked to the use of specific optical codes, such as QR-Code and Markers. Once associated with the specific content, these deposited on a remote server graphics allow the overlay to the real content. In this sense, it is opportune to point out how technology is evolving, to eliminate these barriers.

To overcome the use of optical codes, it points out the direct recognition of images so-called blipping. At the same time, to transform AR into a more complete experience, technological research is moving towards a miniaturization of HMD that goes towards the so-called wearable devices, similar in all to light and technologically advanced glasses.

### 3. CASE STUDY: TESTACCIO RESIDENTIAL DISTRICT IN ROME AND THE FIRST EXPERIMENT OF WIDESPREAD URBAN AUGMENTED MUSEUM

The research described into this paper is aimed at developing guidelines for the definition of an integrated strategy based on the application of AR in external areas to enhance the minor architectural heritage by creating a Widespread Urban Augmented Museum or, in Italian, Museo Urbano Aumentato Diffuso (MAUDi). The main hypothesis is to enhance the minor architectural heritage by reducing the impact of the costs for the recovery of buildings, taking advantage of the new technologies in augmented reality and encouraging the knowledge of the heritage itself through the methods of traditional research. The focus is on the transposition



**Figure 3.**  
*Territorial classification of the site XXXII in Testaccio District,  
Rome.*

of the documental material found during historical, bibliographic and archival research, in multiplatform and open source digital content that could be viewed by all the most common devices. For this reason, the guidelines, which are being edited by the authors of this paper, provided for a digitalization of contents and a creation of digital reconstructions, that can guarantee the highest levels of compatibility. To evaluate the application of these guidelines, the authors experimenting with a group of buildings belonging to the minor architectural heritage, as case study. Among these, it will be the peculiarities of a building that represents the urban fabric of the

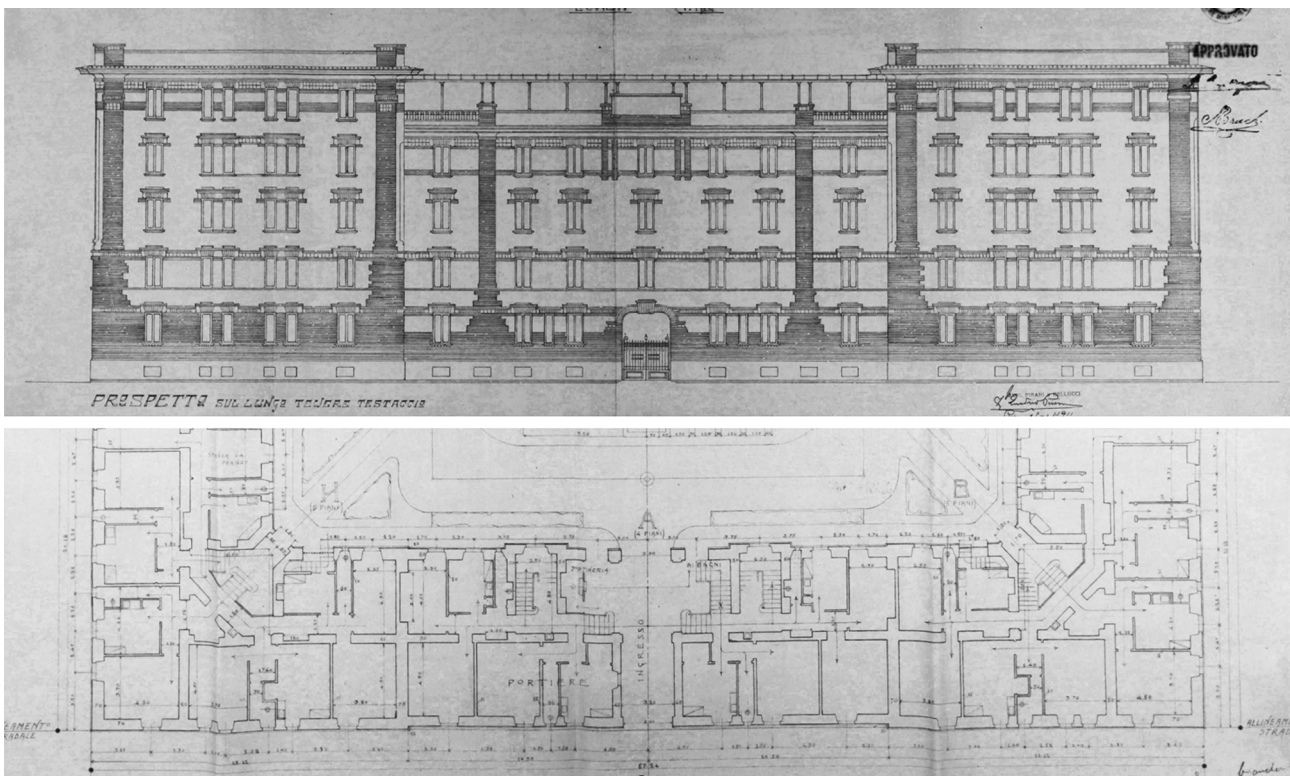

Figure 4.  
Original design documents (source: Archivio Capitolino, Rome).

historic Testaccio district in Rome, precisely the site XXXII, designed and built by Quadrio Pirani (1878-1970). The paper emphasizes the relationship with the context as an intrinsic heritage quality at the basis of his enhancement. The AR contents are the result of research about the construction features of historic buildings and consists in the AR three-dimensional return of some technological details.

### 3.1 HISTORICAL AND TERRITORIAL CONTEXT

After the Unification of Italy and the relocation of the Italian Kingdom Capital to Rome, it became necessary to equip the city with industrial infrastructures that changed the directions of urban expansion. One of the main planning guidelines included the expansion

towards the sea, into a not yet urbanized territory: the gardens near Monte dei Cocci, an artificial hill, stratified over time, by the accumulation of terracotta scrap containers coming from the ancient Roman river port. At the end of the Nineteenth Century, the Mattatoio (meat slaughtering industry) is the first industrial plant that marks the development of the popular roman district of Testaccio. Besides the residential part, some community buildings are completed in the neighborhood, such as the Church of "Santa Maria Liberatrice", designed by the architect Mario Ceradini (1864-1940). It is the witness of how in the first decades of the Twentieth century the technology of reinforced concrete had reached a notable development, for the residences the use of masonry is preferred. In the design there is a renewed

focus on the quality of life of the inhabitants. The square blocks assumed a side dimension between 14 and 20 meters, the full and empty ratio were equal to 0.54 and rules were imposed for the distance between the buildings to guarantee natural illumination and ventilation.

The buildings constituted an almost self-sufficient community: they were perimeter with walls at least one meter high, in the courtyard there was a fountain for the garden care, demonstrating the attention to be paid to common areas and socialization. In addition, there was a bread oven in the courtyard. The buildings had a maximum of 4 floors with inter-floor space from 3.4 to 5.4 meters and they were tinted with light colours on lime plasters for better breathability of the masonry.

The classical language characterized the façades: they presents a tripartite organization with a basement, a scan using stringcourses and a powerful cornice. The buildings are often articulated on the square plan, moving back from the street line determining a better distribution of the windows. The floor plans reveal the massive wall box. The masonry is in pieces of tuff regularized by horizontal courses of bricks every 70 or 80 cm: this technology has characterized the Roman building up to the second post-War period and it derives from the ancient opus listatum or, in italian, muratura listata. It presents the typical tapering by going up: it starts from ordinary foundations in masonry 1 m wide to reach thicknesses ranging from 80 cm at the first floor to 45 cm at the third level. The traditional wooden floors are replaced by those in steel joists and brick vaults or blocks. These floors had false ceilings with the technology of "camera canna" and, to prevent stagnation of humidity, they were ventilated through openings on the façades.

As the urban fabric of Testaccio takes shape, elevations and plans take on more refined configurations, thanks also to Quadrio Pirani. The façades begin to present a very rich embroidery, underlined using bricks in a typical Padano style. With Pirani there is not only a formal configuration: the new blocks provide new community spaces with the functions of nursery and laundry rooms, as in the case of the site XXXII.

### 3.2 TRADITIONAL RESEARCH METHODS AND HERITAGE VALUE

---

In Italy, the great amount of public and private buildings that can aspire to be considered as a minor architectural heritage makes it essential to follow the methods of traditional historical scientific research. Only in this way it is possible both to acquire the material to be processed to allow the supply of increased contents and to determine the classification of the product or of the complex within an index as general as possible. To verify if this methodology is adequate, it is applied to the case study. Lots of information are acquired from archival sources, from the Capitoline Archive (Archivio Capitolino).

The first result of this research is a very detailed planning and constructive timeline from November 1911 to May 1912 and then, in 1917, the works end. It is possible to deduce many dimensional and constructive data from those documents and drawings. The building has width of 14 meter for short fronts up to 40 meters for the longer front, while heights vary from 18.5 to 19.5 meter. The courtyard has dimensions 38 x 32 meters. There are 26 rooms in the basement, 84 shops or warehouses on the ground floor and 89 characteristics. Some of the studied elements were: the large entrance arch, the masonry equipment, the windows variety, the stairs and the crowning of the building.

The portal of the Pirani building is defined by a large round arch that is set on travertine that emerge slightly from the irregular ashlar base. The keystone is enhanced with the same material, model both in perspective and in profile and the concentric rings form a splay denouncing the neo-Romanesque inspiration.

In general, the masonry equipment is of Gothic type, and the tapering in elevation provides that it starts from a six-headed ground attack to get three-headed at the last plane. The use of bricks allows the rich decoration that also characterize the window frames. The window sill denticulated and the architrave simulates a tympanum with different shapes depending on the lines of the windows. The secondary and courtyard, only the top of the window



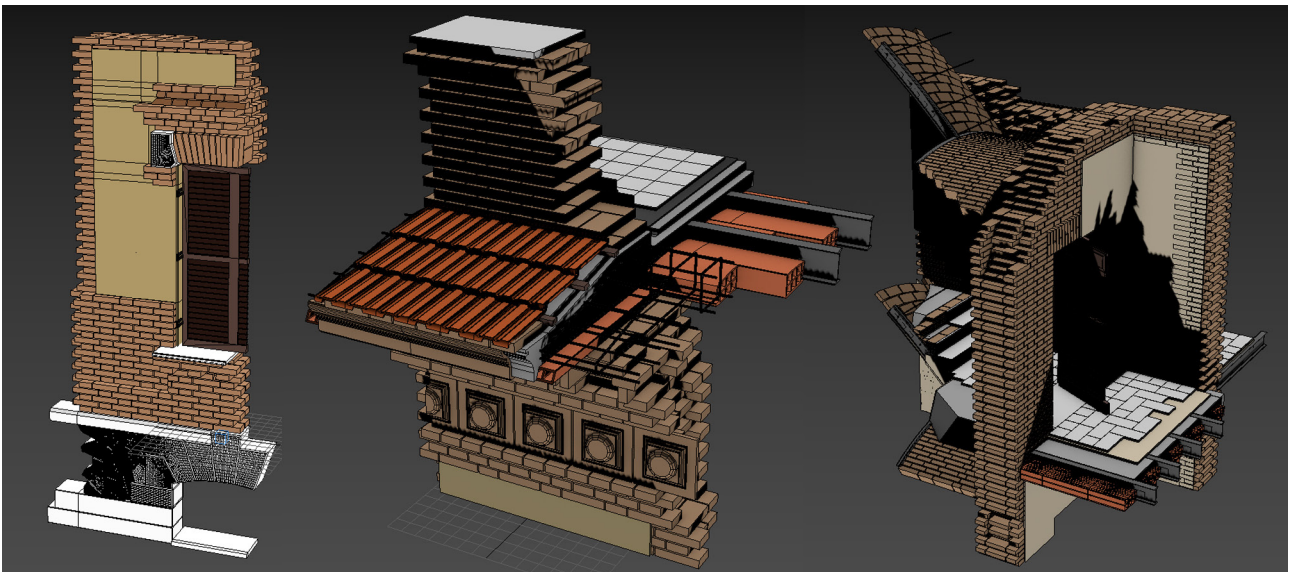

**Figure 5.**  
Some technological details three-dimensional re-constructed to provide augmented contents.

is decorated with a brick slab that emerges from the wall. In correspondence with the bathrooms, the windows have a slot-like shape and in the lower part there is an opening for the ventilation closed by a perforated cast-iron grid. The cornices drawing is very elaborated. The eclectic taste that leads Pirani to define a rich abacus of formal solutions within a single building is not typical of the Roman tradition of those years. On the cornice stands a frieze denticulated with ceramic inserts (metope). There are all the decorations of a classic-inspired cornice: in this building is very marked but it does not correspond to a sloped roof. In fact, the roof is horizontal and practicable at the same level of the laundries. The massiveness of the three-headed parapet provides the necessary interlocking to statically contrast the weights: probably the protruding part is made in reinforced concrete covered by brick-tiles. Those latter are of Marseilles type, that spread from the early Twentieth

century to replace the typical roof with brick-tiles and plane brick-tiles or with brick-tiles and reverse brick-tiles. Pirani doesn't consult the rich abacus of chimney pots typical of that time, but this element has a great importance because it is decorated and of a beautiful shape. The chimneys have a rectangular section and their arrangement once by a face and once by the orthogonal one contributes to the movement of the roof.

### **3.3 CONTENTS DIGITALIZATION AND DISCLOSURE: OPERATIVE GUIDELINES**

For the selected case study, the authors decided to proceed towards the insertion of augmented contents related to the construction technological hypotheses, with the purpose of highlighting reworked contents for agile use. In AR, one of the greatest difficulties is to calibrate the weight in bytes of contents, so that

it can be enjoyed fast without losing quality. It is the case of multimedia, in which video and audio, if not elaborated, could be difficult to transfer in less time.

In case of three-dimensional reconstructions, the models require several polygons, to be sufficiently detailed, proportional both to the level of detail and to the realism of the scene. It can significantly burden the files downloaded by the user. With the aim of applying the described technology in an extensive way, it is necessary that a multiplicity of operators, able in digital restitution, realize the contents to be hosted online.

It needs to operate in two ways: by one side, it is necessary to provide modelling guidelines; by the other side, it is needed to define the output format and some characteristics that allows contents transfer, i.e. to download them by lots of sources.

For the case study, they have been employed modelling tools for the third-dimensional restitution. Using open source software, those models are recompiled to associate them in an information series, related, above all, at the geographic position, at the marker that identify them and at any other information that enrich the AR user experience.

This pack is characterized by light weight for better downloading and it is uploaded into a remote server with a database that contains all his features. To use these contents, it is imagined two flow types for the user. It is imagined a near building special signage with the AR marker. When the user captures this marker with his phone camera, the AR model has been downloaded and the user can view it as a superimposed layer upon the reality. Moreover, it is studied a geotagging-based flow, in which, when the user captures the real subject from any point of view, by his geographic coordinates, an AR model has been downloaded and superimposed upon the camera view. Both tests gave positive results (Baratta et al. 2018).

#### 4. ECONOMIC FEASIBILITY ELEMENTS FOR THE ENHANCEMENT OF MINOR PRIVATE ARCHITECTURAL HERITAGE

By the early twentieth century, industrialized cities in EThe so-called law "Devolution" that reforms the Fifth Title of the Italian Constitution (Titolo V) and the art. number 17 which establishes that the State has exclusive competence in environment, ecosystem and cultural heritage protection, has found its implementation in the Italian Code of Cultural Heritage and Landscape (D.lgs. 42/2004). In this latter law, the "enhancement" is defined as a complex of actions aimed at favoring, even economically, the public enjoyment, knowledge, recovery, redevelopment and conservation of cultural heritage. However, the enhancement of heritage has multiple meanings. To evaluate the enhancement operation feasibility based on the application of Information Communication Technology (ICT) it is very important to dwell on its economic meaning. In this sense, the enhancement must tend to increase the heritage value, or to confer again it to the asset: this value, because of the degradation in which the asset itself is, remains unexpressed. Among the ways in which this can happen, there is also indirect exploitation through the redevelopment of the context. However, it can be affirmed that the reuse of a minor architectural heritage building has a positive regeneration effect on the surrounding urban fabric, in a sort of two-way correspondence. Enhancing the minor architectural heritage increases the cultural offer and acts as an "immaterial development multiplier" (Ippoliti and Meschini, 2010). For some time now, the monumental architectural heritage has been enhanced through using of innovative ICTs. The paper refers to the mobile applications that use the most engaging cultural contents. These technologies are of different types, from Virtual Reality to Augmented Reality (AR), to Mixed Reality, direct filiation of the latter, also effective for reusing of minor architectural heritage. One of the main benefits is linked to the economic characters of the system: if the reuse of architectural heritage is aimed at increasing the cultural offer, with the dissemination of cultural contents, these



**Figure 6.**  
*Viewing overlapped contents in Augmented Reality.*

are used through personal devices already available to user. Furthermore, the infrastructure on which information travels is publicly owned, albeit in private concession. This causes that the costs are reduced to the production of the contents, result of University Research, and to the ICT framework that allows standardization. The costs of the framework are significantly reduced because this is achieved one-off and then only maintained and updated. This concept is very important because technological demand and supply are oriented towards more stable and tested infrastructures or based on widely diffused languages and operating systems (Solima and Minguzzi, 2012).

Once the evaluation of the technical feasibility is ended, the economic feasibility hypotheses of the intervention arises. In a first analysis there are some interesting characteristics that made different the AR intervention from the others enhancing projects. The use of AR as fruition model makes possible to set free the feasibility of the intervention from the costs of transferring the rights (property or enjoyment) claimed on the good. In fact, the good not undergo any change in the conditions of current use. Using AR is not subject to rivalry of use neither between the user and the good, nor between the users themselves. The enjoyment by someone does

not affect the enjoyment of the others and is not invasive for the good itself.

The application for AR is a technological product obtainable at low cost thanks to the use of open source frameworks. Moreover, in terms of diffusion, the cost of the device doesn't weight on the user, thanks to the possible use of private devices (tablets or smartphones).

Virtually, AR is a kind of product that is close to the zero marginal cost production. Once the fixed costs are incurred (i.e. the costs of software implementation) there are no other cost rising associated with the increasing of units produced (variable costs). This feature improves the feasibility profile of the enhancement project.

To verify the feasibility of the intervention, it is important to define the hypothetical starting conditions, in relation to the nature (public or private), both rights owners on the property, and those interested in the operation of enhancement. In short, there are four possibilities: the first two hypotheses concern the possibility that a private entity invests in a private property (first hypothesis) or in a public property (second hypothesis); third and fourth concern the case in which a public entity wants to enhance a private property or a public property. The feasibility of an enhancement initiative against the private entity is not indifferent to the ownership regime of the good. In case of a public property, the intervention will be feasible and fundable by a private entity, only if direct costs (research, development, production and distribution of the framework) are lower than direct revenues. This is possible if the use of AR allows direct or indirect pricing. The first case (direct price) refers to a price imposed on the consumer using the framework (payment of the application, or purchase of additional information packages). In the second case (indirect price) the tariff is not charged to the consumer but is indirectly supported by third parties who use the framework in a different way (i.e. the insertion of advertising). In both cases, the good must be considered worthy by potential users / consumers, and the price of the service have to allows the remuneration of the amount invested. If the private entity intervenes on a private asset, the need

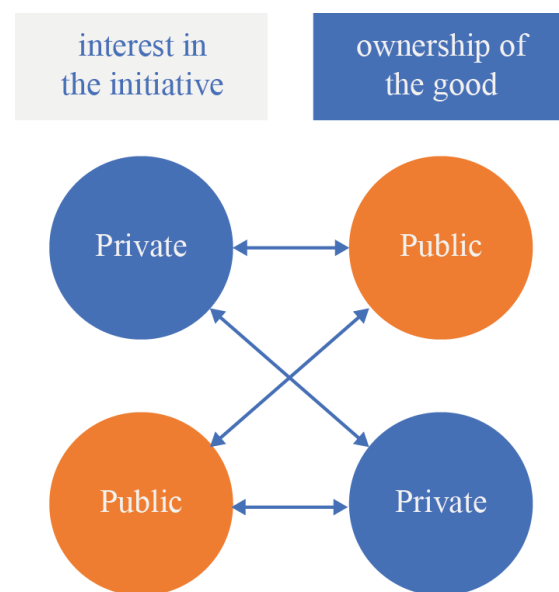

**Figure 7.**  
*Possible basic configurations related to feasibility.*

to remunerate the amount invested in the creation of the framework remains valid as described above. If the investor is also the owner of the asset, the increase in value deriving from the valorisation process can represent the true catalyst for the start of the initiative (as well as an additional income that improves its feasibility profile). Finally, if the private individual is not the owner of the asset, the income deriving from the use of AR should also compensate for the possible cost of acquiring the good itself. However, this situation is far from a concrete hypothesis of feasibility in the case of a minor architectural heritage (such as the subject of this paper) both because the property is obviously fragmented, and because of the difficulty with which the only service provided can allow the recovery of a cost of acquisition.

The scenario is different if the subject interested in the enhancement is public: for this subject the measure of feasibility does not only incur the economic entities related to the size of costs and revenues, but also those of social costs and benefits (falling on the

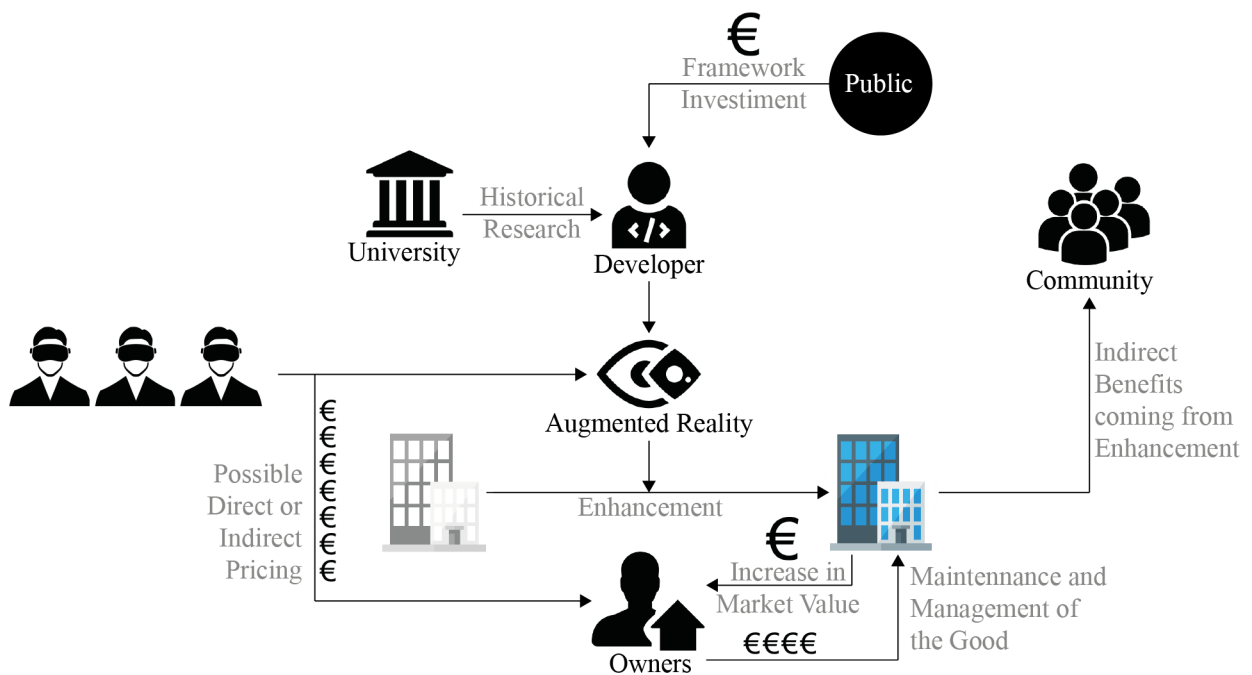

**Figure 8.**  
Probable economic flow triggered by enhancing with augmented reality.

community). The latter, such as positive externality, are also present in a private intervention but, in this case, are not decisive for the choices of the subject. It is in the public intervention that the enhancing succeeds in explaining through its positive externalities all its capacity to generate economic, cultural, social, creative, historical value, in a decisive surplus package for the aim of public choice. In general, the choice of the public subject is connected to the measure of the total social benefits provided by the intervention, which must exceed the total social costs incurred for its implementation. The public subject must be able to verify the measurement of those values (triggered in the enhancing process) which cannot be traced back to the cost and market aspects. For the measure of the increase in value and for the externalities that can be generated by valorisation that are not attributable to the main value aspects (cost and market), the measure of Total Economic Value (T.E.V.) can help.

This criterion measures the utilities deriving from the direct uses of the good, from the indirect ones and from those of existence only (often defined as non-use). With this criterion it is possible to explore all the different nuances of the surplus that the heritage enhancement can generate. Obviously, in the case of a public intervention on a private property (probably the reference model for the minor architectural heritage) also the increase in market value of the good plays an important role, although is an advantage that would fall only on the owner.

About feasibility, the research speculates some of the economic flows that can be triggered in a process like the one described. The public administration can invest resources in the implementation of a low-cost framework, based on the indications provided by the historical research about the private heritage. The framework can provide a mechanism of direct payment (on the consumer) or indirect payment (through

advertising banners) that could partly intended to the owners of the good. In turn, the owners can use part of this amount for the maintenance and care of the heritage or to compensate the annoyance generated by the increase in visitors of the property. Once made the element of a widespread museum, the increase in the prestige of the heritage can lead to increases its market value, a further advantage of the private sector which in turn could lead to greater care for both the good and the context. These mechanisms are transformed again into collective and social benefits; if fully implemented, the system can generate increases in value and create benefits.

For the evaluation, the research is moving towards the application of a stated preferences methods; specifically, at present, the use of Conjoint Analysis (CA) is hypothesised: a multivariate technique that also allows to estimate the value of each attribute that composes a complex offer, such as the cultural one, according to the user.

A set of statistical methodologies makes it possible to study the user choice models, starting from the declarations of their own preferences regarding different profiles of the same product or service. The technique is widespread in the launching on the market of new products or services, because it allows to measure what value is conferred by the user (consumer, even cultural asset) to each attribute that makes up the profile of the product or service (Molteni, 1993). The choice was based on this evaluation technique for its intrinsic ability to provide measurable data in monetary terms (how much is willing to pay the user / consumer) for each attribute of the offer, allowing to recalibrate the same, optimizing it.

By exploiting this model, the research will aim to measure the usefulness that the consumer receives from the specific combination of attributes, while establishing his willingness to pay to use the service. This first measurement would make possible the evaluation of the quantity of resources that can be activated by an enhancement process such as the one under hypothesis in the present contribution, the first step towards defining the feasibility in the various scenarios.

## 5 CONCLUSION AND FUTURE RESEARCH DEVELOPMENTS

---

The main problem encountered in the application of the described guidelines, concerns the extensive application to a Minor Architectural Heritage, the Italian one, difficult even to be registered. To circumscribe the widespread museum to small districts allows to concentrate the economic and human resources on portions of the city to be rediscovered. The possibility of exploiting open source technologies allows to open the digitization of content even outside the University, allowing other researchers to send packaged material, according to the guidelines, thus enlarging the database. In September 2018, the Research Team of the authors is experimenting with the possibility of applying artificial intelligence technologies and neural networks for the interpretation of GIS, BIM and CAD models, in order to be able to autonomously manage the display of the augmented contents, according to the user preferences.

## REFERENCES

Baratta, A., Farroni, L., Finucci, F., Magarò, A. (2018) Nuove tecnologie per il riuso del patrimonio architettonico minore. In Minutoli, F. (ed) Reuso 2018. VI Convegno Internazionale sulla documentazione, conservazione e recupero del patrimonio architettonico e sulla tutela paesaggistica, Gangemi Editore, Roma, IT, pp. 2401-2412.

Bonacina, E. (2014) La realtà aumentata e le app culturali in Italia, *Journal of the department of Cultural Heritage*, 9, 89-122. DOI: <http://dx.doi.org/10.13138/2039-2362/740>

Colavitti, A. M. (2018) *Urban heritage management: planning with history*. Springer, Cham CH.

Ettore, M. A. (2010). "i-MiBAC: un'avanguardia tecnologica per il Ministero per i Beni e le Attività Culturali", *LuBeC 2010*, una finestra virtuale sul futuro dei beni culturali. Multimedialità, nuove professioni e ruolo del pubblico: ecco come cambia la valorizzazione del territorio [WWW document]. URL [archivio.lubec.it/component/content/article/82-lubec-programma/418-interventi.html](http://archivio.lubec.it/component/content/article/82-lubec-programma/418-interventi.html) (accessed 22 October 2018).

Frate, M. C. (2010) *Restauro e conservazione del patrimonio storico*, Dario Flaccovio Editore, Palermo IT.

ICAR (2000) *Atti della Commissione Franceschini. 1967* [WWW document]. URL [archivio.lubec.it/component/content/article/82-lubec-programma/418-interventi.html](http://archivio.lubec.it/component/content/article/82-lubec-programma/418-interventi.html) (accessed 22 October 2018).  
ICCD (2018) *Atrilante dei Centri Storici, sistema webGIS* [WWW document]. URL [151.12.80.71/iccdms/index.html](http://151.12.80.71/iccdms/index.html) (accessed 22 October 2018).

Ippoliti, E., Meschini, A. (2010) Dal modello 3D alla scena 3D. Prospettive e opportunità per la valorizzazione del Patrimonio culturale, architettonico e urbano. *Disegnare con*, 3, 177-191. DOI: 10.6092/issn.1828-5961/2083

Milgram, P., Takemura, H., Utsumi, A., Kishino, F. (1994) *Augmented reality: a class of displays on the reality-virtuality continuum*, *Proceedings of Telematerial and Telepresence Technologies*, SPIE, vol 2351, pp. 282-291 [WWW document]. URL [etclab.mie.utoronto.ca/publication/1994/Milgram\\_Takemura\\_SPIE1994.pdf](http://etclab.mie.utoronto.ca/publication/1994/Milgram_Takemura_SPIE1994.pdf) (accessed 22 October 2018).

Molteni, L. (1993) *L'analisi multivariata nella ricerca di marketing*, Egea, Milano.

Nicolucci, F. (2005) *Technologies for the public understanding of the past: EPOCH's contribution*, *Digital Culture & Heritage, Patrimoine & Culture Numérique* [WWW document]. URL [www.archimuse.com/publishing/iichim05/Nicolucci.pdf](http://www.archimuse.com/publishing/iichim05/Nicolucci.pdf) (accessed 22 October 2018).

Solima, L., Minguzzi, A. (2012) *Relazioni virtuose tra patrimonio culturale, turismo e industrie creative a supporto dei processi di sviluppo territoriale*, *Atti del XXIV Convegno Annuale di Sinergie, il territorio come giacimento di vitalità per l'impresa*, Università di Lecce, Lecce (IT).

Sukigara, T. (2005) *The history information disclosure system by a cellular phone, Smart environments and their application to cultural heritage, a workshop held in conjunction with UbiComp '05*, pp. 57-60.