

ENHANCEMENT OF CONVECTIVE HEAT TRANSFER — NEWTON'S LEGACY PURSUED

ARTHUR E. BERGLES

Troy, New York, USA

1. Historical background

Isaac Newton is widely credited with the following statement of the convective heat transfer coefficient:

$$q = \alpha A(T_{sur} - T_{surr}). \quad (1)$$

Where q is the rate of heat transfer, α the heat transfer coefficient, A the surface area, T_{sur} the surface temperature, and T_{surr} the temperature of the surroundings. The usual reference is a brief paper published in 1701 [1]. While the originator of this attribution is not clear, it is sufficient to note that McAdams made such a statement in 1942 [2] and subsequent authors have followed suit up to the present day [3]. There are difficulties in accepting the historical accuracy of this statement, first, because the paper in question was published anonymously and, second, nowhere in the paper is specifically mentioned a constant of proportionality between heat flux and temperature difference. Indeed, there is sharp criticism of those who would identify Newton with Eq. (1), e.g., [4].

The first problem can be taken care of by noting that Newton actually read the paper at a meeting in May 1701. Furthermore, Newton's laboratory notebooks of 1692 - 93 document the background work for the paper. Anonymous publication was a characteristic of 17th century scientific communication; however, there was rarely any doubt who wrote an article.

The second problem requires considerably more comment. Newton was concerned with the calorimetry needed to fix high and low points on the "Newton temperature scale". His description of the procedure and the mathematics was entirely verbal — in the circuitous style of the times [1]:

"This table was constructed by means of the thermometer and red-hot iron. By the thermometer were found all the degrees of heat, down to that which melted tin; and by the hot iron were discovered all the other degrees; for the heat which hot iron, in a determinate time, communicates to cold bodies near it, that is, the heat which the iron loses in a certain time, is as the whole heat of the iron; and therefore, if

equal times of cooling be taken, the degrees of heat will be in geometrical proportion, and therefore easily found by the tables of logarithms...
 ...there was heated a pretty thick piece of iron red-hot, which was taken out of the fire with a pair of pincers, which were also red-hot, and laid in a cold place, where the wind blew continually upon it, and putting on it particles of several metals, and other fusible bodies, the time of its cooling was marked, till all the particles were hardened, and the heat of the iron was equal to the heat of the human body; then supposing that the excess of the degrees of the heat of the iron, and the particles above the heat of the atmosphere, found by the thermometer, were in geometrical progression when the times are in arithmetical progression, the several degrees of heat were discovered; the iron was laid not in a calm air, but in a wind that blew uniformly upon it, that the air heated by the iron might be always carried off by the wind, and the cold air succeed it alternately; for thus equal parts of air were heated in equal times, and received a degree of heat proportional to the heat of the iron..."

Interpreting this, Newton placed samples of pure metals and alloys on a red-hot, thick piece of iron and noted the times at which the samples solidified as the iron cooled in an air stream. The ratio of the temperature differences was then obtained simply by assuming that this ratio was in geometrical progression when the times were in arithmetic progression. As pointed out in the excellent study by Ruffner [5], however, there is no explicit evidence in any of Newton's writings to explain the logical basis of the procedure. Newton did not state it in the mathematical form of his "fluxions" or calculus. On the other hand, geometrical progressions were widely used by Newton and his contemporaries because they described a variety of physical phenomena. For example, Book II, Proposition II, Theorem II of the *Principia* [6] proposes such a geometrical law for the velocity decay in an object moving by its inertia only in a viscous medium. (Indeed, the idea of a Newtonian fluid stems from the *Principia*, Book II, Section IX.)

In any event, the mathematics was developed subsequently. Briefly, the instantaneous heat flux is assumed proportional to the time rate of change of the iron temperature (assumed to be uniform) and to the temperature difference between the iron and the air:

$$\frac{q}{A} \sim \frac{dT}{dt} \sim T - T_{\infty}. \quad (2)$$

(Although Eq. (1) is often referred to as "Newton's Law of Cooling", Eq. (2) is considered by most to be the proper mathematical statement of the law.) Assuming uniform and equal temperatures of the samples and the iron as well as an invariant constant of proportionality, the temperature for a particular fixed point on the temperature scale is given by:

$$\ln \frac{T_{FP} - T_{\infty}}{T_{body} - T_{\infty}} = \frac{t_{body}}{t_{FP}}, \quad (3)$$

where t_{FP} is the time required to cool to T_{FP} and t_{body} is the time required to cool to body temperature, T_{body} , one of the original fixed points on Newton's temperature scale. A linseed-oil-in-glass thermometer was used by Newton to determine T_{body} and the air temperature, T_{∞} , for the experiments. A typical result was that 57 degrees Newton is the freezing point of a mixture of one part lead and one part bismuth. The inaccuracies in Eq. (3) arise from internal temperature gradients, temperature-dependent convective heat transfer coefficients, and, above all, neglect of radiation.

In view of the present celebration of the 300th anniversary of the Principia, it is natural to inquire whether the heat transfer problem was mentioned prior to 1701 or even prior to the back-up notebooks. Indeed, in Principia, Book III, Proposition XLI, Problem XXI, the "heat of boiling water" and "heat of red-hot iron" are mentioned. It is very likely that Newton had by 1687 already formulated his basic concepts of heat transfer.

To summarize this Newtonian historical prelude, it seems reasonable to conclude that Newton's convective cooling conjecture was established by the time the Principia was published in 1687. In effect, the Principia represents the first publication of his ideas. He elevated the hypothesis to a basic principle in the 1690's as a result of careful experimentation and measurement. The work was finally presented at a meeting and published in 1701. While Newton did not specifically mention a quantity that resembles the convective heat transfer coefficient, the implicit recognition of the role of the coefficient as a constant of proportionality in Eq. (2) seems to be adequate justification to give Newton credit for the heat transfer coefficient. He is thus a heat transfer pioneer as well as a mechanics pioneer, and the Principia should be celebrated for both reasons.

2. Subsequent developments

Equation (2) became known as "Newton's Law of Cooling", certainly by the time of Fourier [7]. In any event, Eq. (1), with α designated the "external conducibility", was used by Fourier as a boundary condition for the heat conduction equation. Fourier also commented on the necessity to consider radiation as well as convection and briefly discussed factors that influence both forced and free convection. It is primarily the radiation that caused deviations from the "law" and, in fact, led to many efforts to discredit the law during the 1700's. An elegant assessment in modern terms of the effect of radiation was given recently by Grigull [8].

Succeeding work was directed toward the accumulation of values of the heat transfer coefficient for a wide range of circumstances. The heat transfer coefficient continued to be referred to as "conductivity" through much of the 1800's [9]. By the time of Nusselt, the present terminology seems to have widely adopted. Nusselt's pioneering 1909 work [10] to correlate heat transfer coefficients is the basis for the modern science of convective heat transfer. It must be pointed out, however that it took several more years before the grouping $\alpha d/k$ (d — a characteristic dimension such as diameter, k — fluid thermal conductivity), now known as the Nusselt number, was specifically mentioned by Nusselt [11].

The art and science of convective heat transfer has grown rapidly in this century.

We now have empirical, analytical, and numerical correlations providing the heat transfer coefficient for almost every conceivable normal situation, i.e., smooth, straight channels with no special body forces. See, for example, well-known handbooks [12, 13]. Within the past twenty years, however, a very substantial movement has developed to go beyond this "First Generation Heat Transfer."

The extension of classical heat transfer has been prompted by the need to develop more efficient heat exchange equipment. Often the goal is to reduce the size of a heat exchanger to deliver a specified heat duty. Alternatively, it may be necessary to upgrade the heat transfer capability of an existing heat exchanger. More effective heat transfer may also be required to prevent excessive temperatures or system destruction in situations where heat generation rates are fixed. This "Second Generation Heat Transfer" is referred to as heat transfer enhancement, augmentation, or intensification.

3. Heat transfer enhancement

3.1. Background. Not surprisingly, Newton himself suggested an effective way of increasing convective heat transfer: "...not in a calm air, but in a wind that blew uniformly upon it..." [1]. The idea indeed is to increase the normal heat transfer coefficient (and possibly the surface area) to achieve the thermal objectives.

Originally based on attempts to develop finned surfaces and turbulators, the art and science of enhancement is progressing rapidly. A great deal of research effort has been devoted to developing apparatus and performing experiments to define the conditions under which an enhancement technique will improve heat (or mass) transfer. The effectiveness of the various techniques is strongly dependent on the modes of heat transfer, which range from single-phase free convection to dispersed flow film boiling.

The increasing interest in heat transfer enhancement is evident from the exponential increase in technical literature, as shown in Fig. 1 [14]. A similar trend is observed with U.S. Patents, which numbered over 450 in 1983 [15]. Indeed, heat transfer enhancement is one of the fastest growing areas in heat transfer and it is estimated that over 500 papers, reports, and patents each year concern this subject. A listing of the various enhancement techniques and the distribution of the citations represented in Fig. 1 is given in Table 1. The passive techniques do not require direct application of external power to bring about the enhancement whereas the active techniques do require external power. Some general observations can be made as to the recent evolution of this technology. The widely scattered literature has been collected, classified, entered into a computerized data base, and published in report form [14, 15]. Sophisticated experiments have been conducted to determine local heat transfer coefficients with complex geometries. Numerical simulations of increasingly complicated configurations are being attempted. Of greatest significance perhaps is the extent to which the more effective and feasible augmentation techniques are graduating from the laboratory to full-scale industrial equipment. Research and development at the present times is need-driven rather than curiosity-driven.

In keeping with the current emphasis on practical applications, the remainder of this paper will primarily discuss areas of application rather than the techniques and their

characteristics because they are now amply discussed in handbooks [12, 13, 16]. The intent is to illustrate the main driving trends that characterize the pursuit of Newton's legacy.

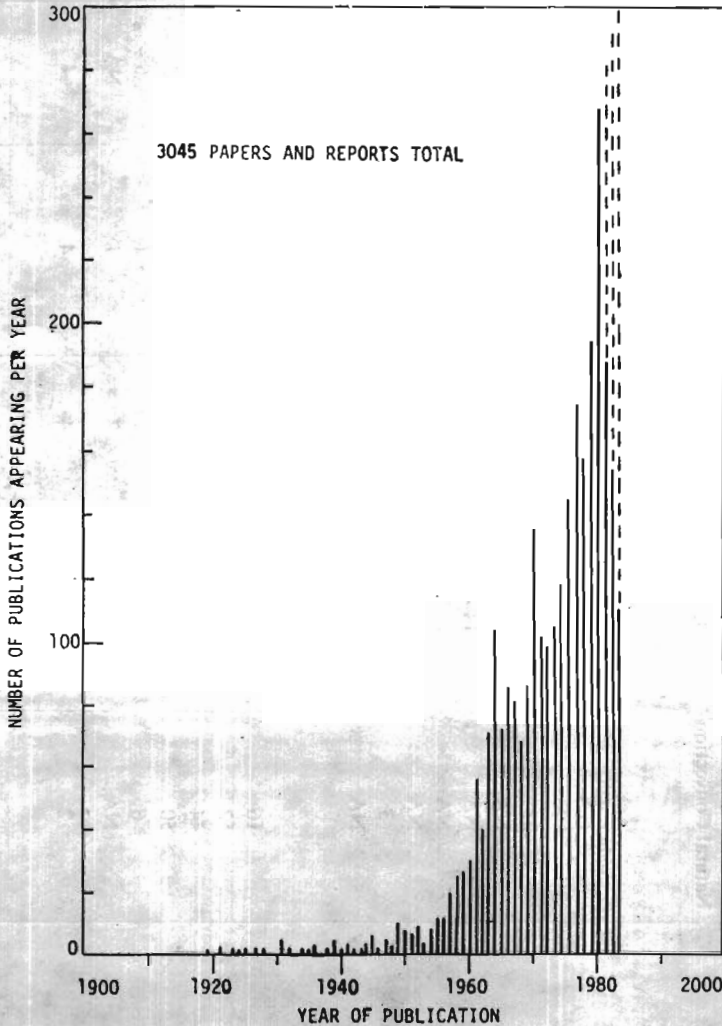

Fig. 1. Annual publications in heat transfer enhancement [14]

3.2. Heating, ventilating, and air conditioning. This industry is well known for its ready adoption of enhancement for both gas-side and liquid-side heat transfer. Air-side heat transfer is routinely improved with fins that are louvered, corrugated, or serrated, as shown in Fig. 2. The intent is to extend the area and increase the heat transfer coefficient. Webb [17] reviews many of the surfaces developed to accomplish this strategy.

Many new surfaces have been developed to enhance boiling and condensation, both shellside and tubeside [18]. Following the early example of the Linde High Flux porous

Table 1. Classification of Enhancement Techniques and Number of Citations in Each Category [14]

	Single-Phase Natural Convection	Single-Phase Forced Convection	Pool Boiling	Forced-Convection Boiling	Condensation	Mass Transfer
Passive Techniques (No external power required)						
Treated surfaces	NA	NA	149	17	53	NA
Rough surfaces	7	418	42	65	65	29
Extended surfaces	23	416	75	53	175	33
Displaced enhancement devices	NA	59	4	17	6	15
Swirl flow devices	NA	140	NA	83	17	10
Coiled tubes	NA	142	NA	50	6	9
Surface tension devices	NA	NA	12	1	NA	NA
Additives for liquids	3	22	61	37	NA	6
Additives for gases	NA	211	NA	NA	5	NA
Active Techniques (External power required)						
Mechanical aids	16	60	30	7	23	18
Surface vibration	52	30	11	2	9	11
Fluid vibration	44	127	15	5	2	39
Electric or magnetic fields	50	53	37	10	22	22
Injection or suction	6	25	7	1	6	2
Jet impingement	NA	17	2	1	NA	2
Compound enhancement (Two or more techniques)	2	50	4	4	4	2
NA = not applicable						

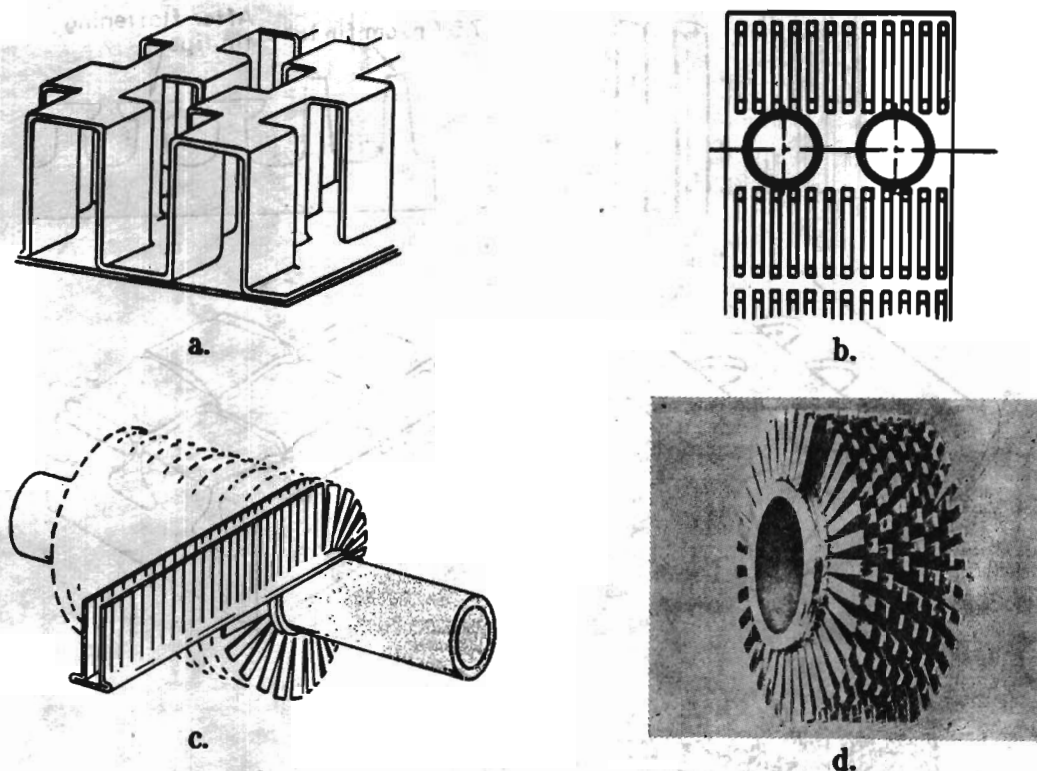

Fig. 2. Enhanced surfaces for gases; a. Offset strip fins, b. Louvered tube-and-plate fin, c. Segmented aluminum serrated fins epoxyed to copper tube, d. Steel serrated fins welded to steel tube.

metallic matrix coating, integral surface structures have been devised to provide large subsurface areas conducive to vapor generation by thin-film evaporation. This and other commercial shell-side boiling surfaces are shown in Fig. 3. Extensive experiments have defined the key geometrical parameters, such as particle diameter, pore diameter, or gap width. Semianalytical models have been proposed for several of the surfaces. The flow and heat transfer are so complex, however, that the modeling is only useful to establish the physics rather than to provide predictive equations. For example, the model for the Thermoexcel-E surface requires eight experimentally determined constants (Nakayama et al. [19]).

Low, integral fins have long been used for enhancement of shell-side condensation of refrigerants. The recent trend has been to carefully configure the fins (Marto [20]) and to use three-dimensional shapes. For both boiling and condensing, tubes are now provided with tube-side enhancements of the inner-fin or spiral repeated-rib style. Some examples are shown in Fig. 4. The "doubly enhanced" tube (Fig. 4b) is indicative of the tendency to provide the highest possible overall heat transfer coefficient.

The traditional star-shaped inserts and annular offset strip fins have given way to small-scale spiral fins for enhancement of in-tube evaporation or condensation. Improvements in average heat transfer coefficients of about 100% are readily achieved, but the

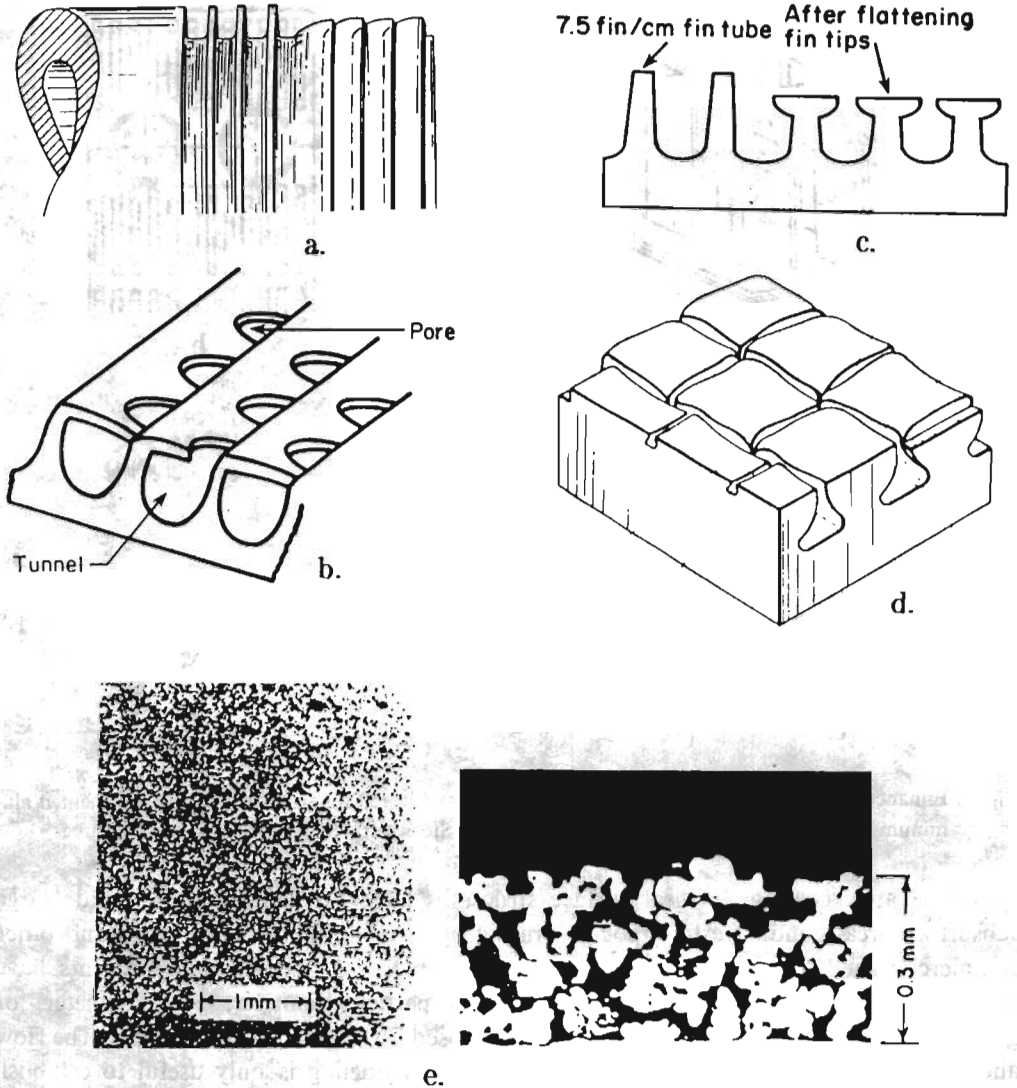

Fig. 3. Enhanced boiling surfaces; a. Rolled-over low fins (Trane Co.), b. Tunnel-and-pore arrangement (Hitachi Thermoexel-E), c. Flattened low fins (Wieland GEWA-T), d. Knurled low fins (Furukawa ECR-40), e. Sintered porous metallic matrix surface (Linde High Flux)

percentage increase in pressure drop is usually less. The manufacturing cost is modest compared to other in-tube enhancements. The commercial application of these "micro-fin" tubes is well ahead of comprehensive experimental delineation of the effects of geometrical variations, and no analytical work has been attempted.

Contemporary areas of concern include boiling and condensing of non-azeotropic refrigerant mixtures that are of interest for heat pumps. While some mixtures have been tested with shell-side boiling and condensing enhancements, the more pertinent in-tube tests have been limited to plain tubes. A second area of concern is the effect of compressor

lubricating oil on refrigerant heat transfer. The general consensus is that the shell-side performance of enhanced tubes is degraded about the same percentage as that for plain tubes. The first comprehensive report of the effects of oil on in-tube evaporation and condensation with enhanced tubes was presented by Schlager et al. [21].

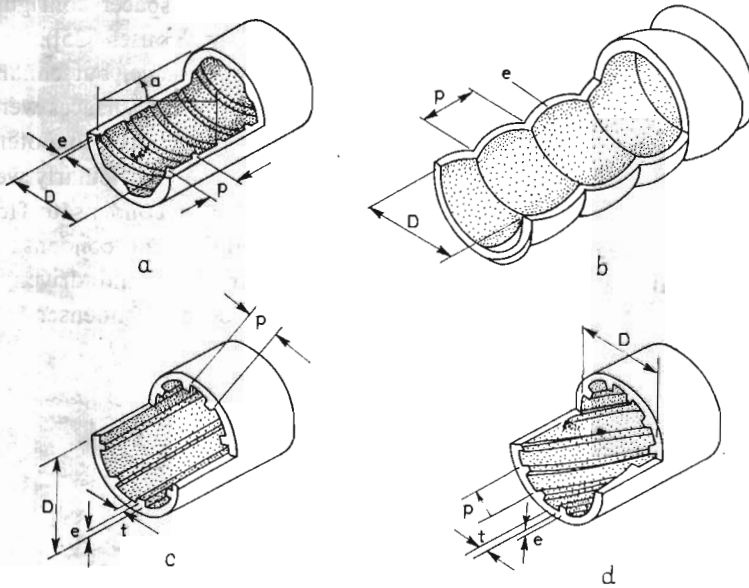

Fig. 4. Typical tube-side enhancements; a. Helical rib roughness, b. Spiral repeated rib, c. Axial internal fins, d. Helical internal fins, Diameter D , protuberance height e , pitch p , thickness t , and angle α are defined

In closing this section, it is worth noting that much of the activity in this industry is motivated by patent protection. New surface configurations and manufacturing methods are being developed to avoid licensing existing technology.

3.3. Automotive. Enhanced air-side surfaces have contributed to the dramatic reduction in size and weight of automotive radiators as well as the other heat exchangers found in modern vehicles. Mori and Nakayama [22] report this reduction to be about 60% from 1957 to 1980. Additional gains have been made in the last 7 years through the use of thin (down to 0.025 mm) copper fin stock that is louvered and tightly packed (up to 2000 fins/m). Considerable progress has been made in the numerical simulation of offset strip fins and louvered fins (e.g., Patankar and Prakash [23]) with laminar flows.

There has been renewed interest in augmentation of the viscous flows that occur in oil coolers. Many types of convoluted channels and mixing inserts have been utilized; however, there is little in the way of analysis or correlations to guide the design. The one exception is twisted-tape inserts which have received considerable attention.

3.4. Power. High-performance air-side surfaces have been developed for dry cooling towers used for fossil power plant heat rejection. Current designs utilize structured boiling surfaces in the intermediate heat exchanger that evaporates the transfer fluid, ammonia.

Internally finned or rifled boiler tubes have been studied in some detail, particularly

under dryout and post-dryout conditions. These tubes delay dryout to higher steam qualities and reduce wall temperatures in dispersed-flow film boiling [24].

Although new nuclear plant construction in the U. S. is nearing a standstill, there is a considerable business in reload fuel. The new bundles have specially designed rod spacers so that the dryout power is increased, thereby allowing an increase of plant power. Some rather sophisticated experiments have been run to define the spacer configurations; however, the data are generally proprietary (Groeneveld and Yousef [25]).

Ocean thermal energy conversion is still in the planning stage, but enhanced boiling and condensing surface are vital to efficient designs. Many of the surfaces were developed for desalination, an area that has not fulfilled its promise relative to potential use of augmentation technology. The design of condensing surfaces is particularly well advanced because of recent analytical studies of surface-tension-driven condensate flow. The enhanced surfaces thus developed are being used for evaporation and condensation of other organic fluids considered for organic Rankine cycles, both fired and driven by geothermal brine. An example of a mathematically optimized vertical condenser tube is shown in Fig. 5 [26].

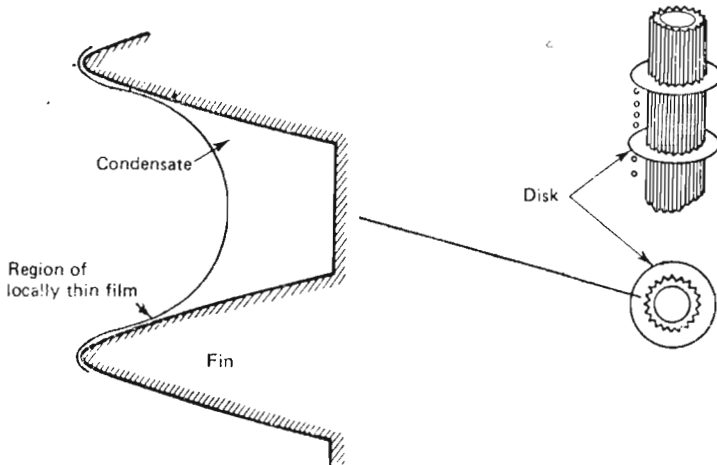

Fig. 5. Ideal fin profile for vertical condensation [26]

3.5. Process. The chemical process industry has adopted augmentation technology sparingly because of concerns about fouling. Plant engineers do not wish to risk shutdown of an entire process facility because of degradation of a heat exchanger that is costwise a small part of the facility. The Cal Gavin Heatex wire loop inserts and Vapor Sphere Matrix fluted spheres (tubeside), or solid spheres (shellside), not only improve heat transfer but reduce fouling with typical process fluids (Mascone [27]). Once again, commercial installation has preceded research on these inserts.

Twisted-tape inserts have been tested with liquids of high viscosity under both heating and cooling conditions. The temperature difference has a strong influence on the heat transfer coefficient; however, the data are quite well correlated with a wall-to-bulk viscosity ratio correction similar to that used for smooth tubes. It has recently been shown

numerically, with experimental confirmation, that tape twist has little effect on liquids of extreme viscosity; the enhancement is due simply to segmenting the tube. A general correlation of twisted tape performance in uniform temperature tubes was recently presented by Manglik and Bergles [28].

Some attention has been given recently to the augmentation of heat transfer to laminar-in-tube flow of non-Newtonian liquids. Percentage improvements in heat transfer coefficients with spirally corrugated tubes and twisted-tape inserts are comparable to those observed with Newtonian liquids.

The High Flux surface has been noted in connection with refrigeration applications, but its main application is in process plant reboilers. Numerous technical papers and economic analyses have been directed toward this application.

3.6. Industrial heat recovery. Advanced surfaces for high-temperature heat recovery are being designed so that both convection and radiation are enhanced. Of particular interest recently are ceramic tubes that are enhanced externally and/or internally. These tubes show great promise for the recovery of heat from waste streams in excess of 800°C [29].

Fouling and corrosion must be minimized if high-temperature heat recovery is to be practical. While most studies of fouling are with plain surfaces, serrated finned tubes and offset-strip-fin heat exchangers have been studied. These surfaces may remain effective in moderate fouling conditions; however, it is possible that nearly total plugging occurs with certain streams, e.g., diesel exhaust and glass furnace exhaust.

3.7. Electronics cooling. Enhanced extended surfaces have long been used for air cooling of electronic devices ranging from radar tubes to transistors. The recent emphasis has been on the development of cooling schemes for microelectronic chips used in computers. Structures are provided to conduct the heat generated by an array of chips out to the air or water coolant. The final thermal coupling is through finned arrays that may be quite complex for air cooling or simple for liquid cooling. At present, much attention is being given to direct immersion of the chips in an inert, dielectric liquid. Saturated or subcooled boiling occurs due to the high chip powers. With the dual objective of reducing the wall superheat and increasing the burnout heat flux, enhanced boiling surfaces are attached to individual chips (Park and Bergles [30]). There is much work yet to be done to establish configurations that achieve both objectives.

Jet impingement of dielectric liquid has recently been explored as a means of accommodating very high chip heat dissipations (over $2 \times 10 \text{ W/m}^2$).

3.8. Aerospace. Gas turbine blade cooling has challenged the heat transfer community for the past decade. Several enhancement techniques are now being utilized to increase the heat transfer coefficient from blade wall to internal coolant, thereby reducing the wall temperature. Transverse repeated ribs and pin fins can be cast into the blade, or the air supply can be arranged to direct jets against the leading-edge wall [31].

Difficult heat transfer problems are being encountered in connection with the aerospace plane proposed for transatmospheric flight. In addition to protection of components in the propulsion system, active cooling of the vehicle will likely be required to reduce material temperatures during hypersonic flight. Enhancement of heat transfer will probably be required.

3.9. **Some general developments and issues.** The preceding collection of recent applications of heat transfer enhancement technology should confirm that this is indeed a very active area of heat transfer research and development. Several additional comments are presented in closure to this section.

Although accorded a prominent section in Table 1, it is evident that there is now much less interest in active enhancement techniques. The literature and the applications are dominated by surfaces and inserts for passive enhancement.

The systematic development of performance evaluation criteria was undertaken in the early 1970's. Significant progress has been made by including entropy generation among the parameters of interest and by developing complete tables of possible criteria. The first paper directed entirely toward criteria for evaporation and condensation was recently presented [32].

Numerical simulations are being successfully carried out for increasingly complicated flow situations. As an example, the large enhancement that occurs in rectangular channels with transversely grooved walls, when the laminar core flow is modulated at the natural frequency, has been accurately predicted [33].

Design correlations are the object of many of the recent studies. The object is to have the geometrical effects adequately described so that the surface can be fabricated in the optimum configuration, perhaps as dictated by the desired performance evaluation criterion. The correlations may be based in part on fundamental principles, such as the heat transfer — momentum transfer analogy, or they may be purely empirical, derived from the comprehensive data bases now available.

Most heat exchangers are now being designed by computer because of increasing computer power and the rapidly growing supply of software (Palen [34]). Programs for many of the common heat exchanger types include options for enhanced tubes or inserts.

4. Conclusions

The enhancement of convective heat transfer has indeed become a second generation heat transfer technology that is called upon with increasing frequency in industrial practice. Newton can be credited with the underlying concepts of convective heat transfer including an understanding of some factors that enhance the convection. It is thus appropriate that this tricentennial celebration of the Principia by the Polish Society of Theoretical and Applied Mechanics recognizes Newton's pioneering work in heat transfer as well as his contributions to solid and fluid mechanics.

References

1. I. NEWTON, *Scala Graduum Caloris*, The Philosophical Transactions of the Royal Society of London, v. 22, 1701, pp. 824—829. Translated from the Latin in Philosophical Transactions of the Royal Society of London, Abridged, v. IV (1694—1702), London, 1809, pp. 572—575
2. W. H. MCADAMS, *Heat Transmission*, 2nd Edition, McGraw-Hill, New York, p. 3.
3. W. S. JANNA, *Engineering Heat Transfer*, PWS Publishers, Boston, 1986, p. 16.

4. E. F. ADIUTORI, *The New Heat Transfer*, Ventuno Press, Cincinnati, 1974, p. 1 - 11.
5. J. A. RUFFNER, *Reinterpretation of the Genesis of Newton's Law of Cooling*, *Archive for History of Exact Sciences*, v. 1, 1960 - 1962, pp. 138 - 153.
6. I. NEWTON, *Philosophiae Naturalis Principia Mathematica*, S. Pepys, London, 1687. A. Motte 1729 English translation in the F. Cajori edition, University of California Press, Berkeley, 1934.
7. J. FOURIER, *The Analytical Theory of Heat*, 1822, translated from the French, Dover, New York, 1955, p. 29, etc.
8. U. GRIGULL, *Newton's Temperature Scale and the Law of Cooling*, *Wärme — und Stoffübertragung*, v. 18, 1984, pp. 195 - 199.
9. J. P. JOULE, *On the Surface-Condensation of Steam*, *Philosophical Transactions of the Royal Society of London*, v. 151, 1861, pp. 133 - 160.
10. W. NUSSELT, *Der Wärmeübergang in Rohrleitungen*, *Mitt. Forschungsarb. Ing. Wesen*, v. 89, 1909, pp. 1 - 38.
11. W. NUSSELT, *Das Grundgesetz des Wärmeüberganges*, *Gesundh. Ing.*, v. 38, 1915, pp. 337 - 482, 490 - 496.
12. E. U. SCHLÜNDER et. al., *Heat Exchanger Design Handbook*, Hemisphere, Washington, D. C., 1983.
13. W. M. ROHSENOW, J. P. HARTNETT, E. N. GANIC, Editors, *Handbook of Heat Transfer Fundamentals*, and *Handbook of Heat Transfer Applications*, McGraw-Hill, New York, 1985.
14. A. E. BERGLES, V. NIRMALAN, G. H. JUNKHAN, R. L. WEBB, *Bibliography on Augmentation of Convective Heat and Mass Transfer — II*, HTL-31, ISU-ERI-Ames-84222, DE-84018484, Iowa State University, Ames December 1983.
15. R. L. WEBB, A. E. BERGLES, G. H. JUNKHAN, *Bibliography of U. S. Patents on Augmentation of Convective Heat and Mass Transfer — II*, HTL-32, ISU-ERI-Ames-84257, DE-84014865, DOE/ID/12222-T1, Iowa State University, Ames, December 1983.
16. R. L. WEBB, *Special Heat Transfer Surface Geometries*, in *Handbook of Single-Phase Convective Heat Transfer*, Wiley, New York, 1987.
17. R. L. WEBB, *Air-Side Heat Transfer in Finned Tube Heat Exchangers*, *Heat Transfer Engineering*, v. 1 (3), 1980, pp. 33 - 49.
18. R. L. WEBB, *The Evolution of Enhanced Surface Geometries for Nucleate Boiling*, *Heat Transfer Engineering*, v. 2 (3 - 4), 1981, pp. 46 - 69.
19. W. NAKAYAMA, T. DAIKOKU, H. KUWHARA, T. NAKAYAMA, *Dynamic Model of Enhanced Boiling Heat Transfer on Porous Surfaces, Part II: Analytical Modeling*, *Journal of Heat Transfer*, v. 102, 1980, pp. 451 - 456.
20. P. J. MARTO, *Recent Progress in Enhancing Film Condensation Heat Transfer on Horizontal Tubes*, *Heat Transfer* 1986, v. 1, *Proceedings of the 8th International Heat Transfer Conference*, 1986, pp. 161 - 170.
21. L. M. SCHLAGER, A. E. BERGLES, M. B. PATE, *A Survey of Refrigerant Heat Transfer Pressure Drop Emphasizing Oil Effects and In-Tube Augmentation*, *ASHRAE Transactions*, v. 93, Part 1, 1987.
22. Y. MORI, W. NAKAYAMA, *Recent Advances in Compact Heat Exchangers in Japan*, HTD-v. 10, *Compact Heat Exchangers — History, Technological Advancement and Mechanical Design Problems*, ASME, New York, 1980, pp. 5 - 16.
23. S. V. PATANKAR, C. PRAKASH, *An Analysis of the Effect of Plate Thickness on Laminar Flow and Heat Transfer in Interrupted — Plate Passages*, *International Journal of Heat Transfer*, v. 24, 1981, pp. 1801 - 1810.
24. J. B. KITTO, Jr., M. J. ALBRECHT, *Elements of Two-Phase Flow in Fossil Boilers*, Presented at NATO Advanced Study Institute on Thermal Hydraulic Fundamentals and Design of Two-Phase Heat Exchangers, Pavia de Varzim, Portugal, July 1987.
25. D. C. GROENEVELD, W. W. YOUSEF, *Spacing Devices for Nuclear Fuel Bundles: A Survey of Their Effect on CHF, Post-CHF Heat Transfer and Pressure Drop*, *Proceedings of the ANS/ASME/NRC International Topical Meeting on Nuclear Reactor Thermal-Hydraulic*, NUREGI/CP 0014, v. 2, 1980, pp. 1111 - 1130.
26. Y. MORI, K. HIJIKATA, S. HIRASAWA, W. NYKAYAMA, *Optimized Performance of Condensers with Outside Condensing Surfaces*, *Journal of Heat Transfer*, v. 103, 1981, pp. 96 - 102.

27. C. F. MASCONI, *CPI Strive to Improve Heat Transfer in Tubes*, Chemical Engineering, February 1986, pp. 22 - 25.
28. R. M. MANGLIK, A. E. BERGLES, *A Correlation for Laminar Flow Enhanced Heat Transfer in Uniform Wall Temperature Circular Tubes with Twisted-Tape Inserts*, Advances in Enhanced Heat Transfer—1987, HTD-v. 68, ASME, 1987, pp. 35 - 45.
29. A. E. BERGLES, *Heat Transfer Enhancement — Applications to High-Temperature Heat Exchangers*, Heat Transfer in High Technology and Power Engineering, Hemisphere and Springer-Verlag, 1987, pp. 333 - 355.
30. K.-A. PARK, A. E. BERGLES, *Boiling Heat Transfer Characteristics of Simulated Microelectronic Chips with Detachable Heat Sinks*, Heat Transfer 1986, v. 4, Proceedings of the 8th International Heat Transfer Conference, 1986, pp. 2099 - 2104.
31. R. J. SIMONEAU, *Heat Transfer in Aeropropulsion Systems*, Heat Transfer in High Technology and Power Engineering, Hemisphere and Springer-Verlag, 1987, pp. 285 - 319.
32. R. L. WEBB, *Performance Evaluation Criteria for Enhanced Tube Geometries Used in Two-Phase Heat Exchangers*, Proceedings of the India-U. S. Advanced Study Institute, Poona, June 1986 (to appear in Heat Transfer Equipment Design, Hemisphere, 1988).
33. M. GREINER, N. K. GHADDAR, B. B. MIKIC, A. T. PATERA, *Resonant Convective Heat Transfer in Grooved Channels*, Heat Transfer 1986, v. 6, Proceedings of the 8th International Heat Transfer Conference, 1986, pp. 2867 - 2872.
34. J. W. PALEN, *Designing Heat Exchangers by Computer*, Chemical Engineering Progress, July 1986, pp. 23 - 27.

Резюме

ИНТЕНСИФИКАЦИЯ КОНВЕКЦИОННОГО ПРОНИКАНИЯ ТЕПЛА — — ПРОДОЛЖЕНИЕ НАСЛЕДСТВА НЬЮТОНА

Рассматривание предпосылок „Ньютоновского Закона Охлаждения” приводит к заключению, что идею коэффициента конвекционного проникания тепла следует приписать Нютону. Так как первые эксперименты с теплом упоминаются уже в Principia мы должны признать его пионером в области проникания тепла, так в механике твердого тела как и жидкости. Наследство Ньютона содержит также реализацию тех фактов, которые улучшают коэффициент проникания тепла, доставляя первых основ для возникающей науки о интенсификация проникания тепла. Эту „вторую генерацию техники проникания тепла” рассматриваем с точки зрения текущих областей применений в технике.

Streszczenie

INTENSIFYKACJA KONWEKCYJNEGO PRZENIKANIA CIEPŁA — KONTYNUACJA DZIEDZICTWA NEWTONA]

Rozpatrywanie podstaw „Newtonowskiego Prawa Chłodzenia” prowadzi do wniosku, że koncepcja współczynnika konwekcyjnego przenikania ciepła jest zasługą Newtona. Ponieważ dawne doświadczenia z ciepłem zostały wspomniane w „Principiach” należy uznać go jako pioniera w dziedzinie przenikania ciepła, zarówno w mechanice ciała stałego jak i cieczy. Spuścizna Newtona zawiera również realizację tych czynników, które polepszają współczynnik przenikania ciepła, dostarczając najstarszej podstawy dla powstającej nauki o intensyfikacji przenikania ciepła. Tę „drugą generację techniki przenikania ciepła” rozpatrujemy z punktu widzenia bieżących dziedzin zastosowań w technice.

Praca wpłynęła do Redakcji dnia 26 października 1987 roku.