

ASSESSMENT EFFECTIVENESS ANALYSIS SYSTEM USING G-FORM WITH TAM METHOD AT SD GALATIA3 JAKARTA BARAT

Asrul Sani^{1*}, Agus Budiyantra², Rizaldy Khair³, Siti Aisyah⁴

^{1,2} Informatics Engineering Study Program
STMIK Widuri

Jakarta, Indonesia

www.kampuswiduri.ac.id

asrul.5779@gmail.com; agusbudiyantra@kampuswiduri.ac.id

³ Computer Technology Study Program

Polytechnic LP3I Medan

Medan, Indonesia

www.plm.ac.id

rizaldy.khair@plm.ac.id

⁴ Graphic Engineering Study Program

Politeknik Negeri Media Kreatif

Medan, Indonesia

www.polimedia.ac.id

sitiaisyah@polimedia.ac.id

(*) Corresponding Author

Abstract

Peserta didik merasakan dampak dari penyebaran Covid-19 seperti perubahan penyediaan layanan dalam lembaga pendidikan, seperti pendidikan formal pada semua tingkatan, pendidikan non-formal, sampai akademi. Berdasarkan pengumuman Kementerian Pendidikan dan Kebudayaan Nomor 4 Tahun 2020 tentang Pelaksanaan Kebijakan Pendidikan pada Masa Darurat Penyebaran virus Corona (Covid-19). Pemerintah mulai memberlakukan sistem pembelajaran daring (dalam jaringan). Masalah yang muncul selama masa pembelajaran daring ini adalah, masih banyak orang yang belum siap dalam menghadapi teknologi, baik dari segi pengajar maupun pelajar, hal ini terjadi di awal-awal masa pandemi. Sehingga proses pembelajaran yang selama ini dilaksanakan secara normal, baik dalam hal mengajar hingga memberikan penilaian juga mengalami hambatan. Hal ini dikarenakan tenaga pengajar (guru) selalu memiliki data penilaian harian yang biasa dilakukan sehari-hari selama pembelajaran normal. Namun selama masa PJJ ini guru-guru jadi bingung dalam memberikan penilaian harian pada siswanya. Tujuan Penelitian untuk menganalisa dan mengevaluasi sistem pembelajaran daring menggunakan Platform yang mudah dioperasikan oleh guru dan bisa diakses dimana saja yaitu google form. Di aplikasi Google Form terdapat suatu sistem perhitungan otomatis berupa feedback siswa dimana guru tidak repot melakukan perhitungan secara manual terhadap hasil evaluasi belajar siswa. Metode Analisis yang digunakan adalah Technology Acceptance Model (TAM) yang mampu untuk mengetahui sikap para pengguna terhadap teknologi yang digunakan, sehingga para guru mudah mengetahui apakah tugas yang diberikan ke siswa dikerjakan sendiri oleh siswa bukan bantuan orang tua.

Keywords: TAM; Covid-19; Platform; Google Form; Application

Abstract

Students feel the impact of the spread of Covid-19, such as changes in the provision of services in educational institutions, such as formal education at all levels, non-formal education, to academics. The government began to implement an online learning system (online). The problem during this online learning period is that many people are still not ready to face technology, both teachers and students. It happened in the early days of the pandemic. It results in challenges for the standard learning process, including challenges for teaching and giving assessments. It is because the teaching staff (teachers) always



have daily assessment data that is usually carried out daily during everyday learning. However, during this PJJ period, teachers became confused about giving daily assessments to their students. The research aims to analyze and evaluate the online learning system using a platform that is easy to operate by teachers and can be accessed anywhere, namely Google Forms. In the Google Form application, there is an automatic calculation system in the form of student feedback where teachers do not bother to manually calculate the results of student learning evaluations. The analysis method used is the Technology Acceptance Model (TAM), which can determine users' attitudes towards the technology used, so that teachers can easily find out whether the tasks given to students are done by the students themselves, not with the help of parents.

Keywords: TAM; Covid-19; Platform; Google Form; Application

INTRODUCTION

The Covid-19 pandemic from the beginning of 2020 impacted every aspect of Indonesia, including education. Indonesian government policy in mid-March 2020 through the Ministry of Education and Culture and the Ministry of Religious Affairs of the Republic of Indonesia. Implement a work-from-home policy. The government's demands during the pandemic related to the learning process have become a new polemic in the learning system in Indonesia. It is undeniable that teachers must adapt their teaching methods to the needs of current students, especially during a pandemic. It is necessary to change the education system that aims to accommodate the needs of students. Online learning (online) has become familiar today, and online learning meets students' learning needs during the pandemic (Baety & Munandar, 2021). However, it is denied that it also poses obstacles to education. The problem that occurs with the emergence of new barriers related to learning is a problem that has been studied in depth (Handarini & Wulandari, 2020). Obstacles in the learning process can result in a decrease in student interest in learning. One of the obstacles is the teachers' limited ability in the information and communication technology field. According to the Minister of National Education Number 16 of 2007, ICT competence for teachers has at least two functions: ICT as self-development and ICT as a support for learning. This study aims to make it easier for teachers/teaching staff to carry out the online learning process during the pandemic, from teaching to daily assessments. By utilizing platform technology and google forms, teachers can minimize difficulties in terms of learning and evaluation so that teachers easily get learning feedback followed by their students, whom parents can help at home. This research was conducted at SD Galatia 3 West Jakarta. The urgency in this study is to assist teachers in assessing students' daily activities during learning at home. Utilization of google form technology for feasibility research to evaluate daily

student behavior (Munawaroh et al., 2021). This research is very relevant to the RIRN 2017-2045 in the field of Information and Communication Technology, then PRN 2020-2024 on the theme framework/platform supporting the creative industry and control in the field of education.

The objectives of this study are as follows:

1. Analyzing and evaluating the online learning system using Google Forms for Daily Assessment.
2. To find out the responses of students and teachers to the use of Google Forms as an evaluation tool for Daily Assessment.
3. To find out the shortcomings in the use of the Google Form for Daily Assessment

RESEARCH METHODS

The idea of user attitudes and behavior served as the foundation for this study, which led to an emphasis on TRA from viewpoints examined from a psychological standpoint (Ayuni et al., 2020). On this TRA principle, we can know how much we measure the relevant attitude components of a person's behavior, group between beliefs and attitudes, and determine external stimuli so that the reaction and perception of users caused by this TRA model to the information system determined by the attitude and behavior of the user. Then in 1986, Davis conducted dissertation research that adapted the TRA, and Davis disseminated the results of his dissertation research to the journal MIS Quarterly in 1989. Then from the effects of his dissertation research conducted by Davis, a theory called TAM (Technology Acceptance Model) emerged, which emphasizes the perception of ease of use and usefulness, which has to do with predicting the attitude toward using information systems. The TAM model's application is much wider than the TRA model (Darna & Herlina, 2018; Fatmawati, 2015). The TAM model is the basis for evaluating user behavior attitudes in using technology based on

its use from the beginning to the end of use which can be seen in **Figure 1** below:

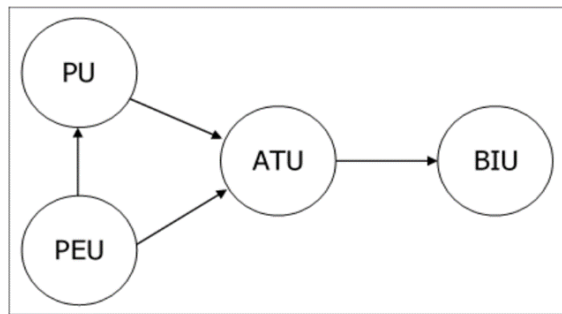

Figure 1. TAM Construction Structure

Information:

PU = Perceived Usefulness
PEU = Perceived Ease of Use
ATU= Attitude Toward Using
BIU = Behavioral Intention to Use

Types of research

This research uses a quantitative approach to collecting data through interviews, observations, literature studies, and questionnaires. The questionnaire will distribute to 85 students of Galatian Elementary School 3. In making the questionnaire, the author adopted the Technology Acceptance Model (TAM) technology as a process (Mulatsih, 2020), which will later be translated into a questionnaire in the Form of a Google Form by taking the variables contained in the TAM, namely Perceived Ease Of Use, Perceived Usefulness, Attitude Toward Using, and Behavioral Intention To Use. From these variables will be created five questions each. The software used by the author to process quantitative data is Statistical Product and Service Solutions (SPSS). SPSS is a unique program for processing statistical data and is known to be reliable in assisting researchers in testing and analyzing statistical information.

Time and Place of Research

The study is approximately four months, from March 2022 to July 2022. The study location

was at the Galatia 3 Elementary School (SD), West Jakarta.

Research Targets/ Subjects

In this study, the author chose the target/subject of the study, namely teachers in grades 1-6 of SD Galatia 3, based on the results obtained by the author concluding that SD Galatia 3 uses Google form to conduct Daily Assessments carried out since the Covid-19 pandemic and the implementation of distance learning rules in 2020. In grades 1-5, teachers using Google Forms to conduct Daily Assessments are considered ineffective because of complaints from students about poor internet networks and sometimes Google Form links to have problems. Meanwhile, the grade 6 teacher's opinion on using Google Forms to conduct a Daily Assessment considers very effective because there have been no complaints from students until now (Erawati et al., 2017). Google Form is more practical, easy, and precise because it can see the grades directly, and children only click on the Google Form link shared by the teacher, after which the child can already do the Daily Assessment so that they do not need to download the Google Form application. Therefore, teachers choose Google Forms to conduct Daily Assessments for their students. The advantage of Google Forms for teachers to do Daily Assessments is that it is more than time-saving, does not need corrections, can immediately see their student's grades, and is easier and more practical to use. Other applications besides Google Forms to conduct Daily Assessments are Google Classroom and Quizizz. The shortcomings of the Google Form for teachers to conduct Daily Assessments are that teachers cannot monitor children's work directly and cannot know whether the child has done it or not before the child submits. In addition, the Daily Assessment is also used to fill in student biodata, practice questions, and quizzes (Rijali, 2018; Sani et al., 2021).

From the results of collecting questionnaire data on students of SD Galatia 3, totaling 77 students, there were several demographic categories of respondents, namely:

Table 1. Demographics of Respondents

No	Category	Limitation	Sum	Overall Number	Percentage
1	Age	6-7 years	24 students	77 students	31,2%
		8-9 years	23 students		29,9%
		10-12 years	30 students		39%
2	Gender	Man	43 students	77 students	55,8%
		Woman	34 students		44,2%
3	Class	1 SD	18 students	77 students	23,4%
		2 SD	9 students		11,7%

No	Category	Limitation	Sum	Overall Number	Percentage
		3 SD	12 students		15,6%
		4 SD	15 students		19,5%
		5 SD	11 students		14,3%
		6 SD	12 students		15,6%
4	Are you guys able to use	Yes	74 students	77 students	96,1%
		No	3 students		3,9%
5	Whether in using Google Forms to do daily assessments, you are still accompanied by parents?	Yes	40 students	77 students	52%
		No	37 students		48,1%
6	Are there any network constraints when working on the Daily Assessment in Google Form?	Yes	36 students	77 students	46,8%
		No	41 students		53,2%
7	Do you use a device in the form of a cellphone in filling out the Daily Assessment on Google form?	Yes	64 students	77 students	83,1%
		No	13 students		16,9%
8	Do you use a device in the form of a laptop to fill out the Daily Assessment on Google form?	Yes	13 students	77 students	16,9%
		No	64 students		83,1%
9	Whether the device you are using is your own?	Yes	71 students	77 students	92,2%
		No	Six students		7,8%

Based on the table above, the demographic categories of respondents' data are viewed based on age, gender, class, and demographic categories of respondents in terms of application can be seen based on six questions, namely, Can you use Google form? Is it in using Google Forms to do The Daily Assessment? Do your parents still accompany you?, Are there any network problems when working on the Daily Assessment on Google form?, Do you use a device in the form of a cellphone in filling out the Daily Assessment on google Form?, do you use a device in the form of laptop in filling out the Daily Assessment in Google form?, and Is the device you are using its own?. Described according to the data obtained from respondents, namely the age of 6-7 years, totaling 24 students with a percentage of 31.2%, aged 8-9 years, totaling 23 students with a percentage of 29.9%, aged 10-12 years totaling 30 students with a percentage of 39%. Then the male sex amounted to 43 students, the percentage was 55.8%, and the female sex was 34 students, 44.2%. Furthermore, in grade 1 elementary school, there are 18 students with a percentage of 23.4%, grade 2 elementary schools are nine students with a percentage of 11.7%, grade 3 elementary schools are 12 students with a percentage of 15.6%, classes Four elementary schools totaled 15 students with a percentage of 19.5%, grade 5 elementary schools totaled 11 students with a percentage of 14.3%, and

finally, grade 6 elementary schools totaled 12 students with 15.6%. In terms of application, as many as 74 students can use Google Form with a percentage of 96.1%, so it concluded that most elementary school students could use Google Forms well. Then the students whose parents accompanied them in using the Google Form to work on the Daily Assessment 40 students, with a percentage of 52%, and those whose parents did not attend as many as 37 students, with a percentage of 48.1%, so concluded that most elementary school students are still accompanied when using Google Form to do the Daily Assessment. Furthermore, as many as 36 students experienced network problems when working on the Daily Assessment on Google Forms, 46.8%, and those who did not experience network problems amounted to 41 students, 53.2%. Hence, it concluded that most elementary school students do not experience network problems when working on the Daily Assessment on Google Forms. Then as many as 64 students used cell phone devices to fill out the No Category Limit total number Percentage 9. Is the device you are using your own? Yes, 71 students, 77 students 92.2% Not six students 7.8%47 Daily Assessment on Google Form with a percentage of 83.1% and in addition to mobile phones, the devices used to fill out the Daily Assessment on Google Form are laptops totaling 13 students with a percentage of 16.9%, so concluded that most elementary school students use mobile

phones in filling out the Daily Assessment on Google Form. The devices used are mostly owned by themselves, with 92.2% of 71 students.

Procedure

In the initial procedure, this research went through several stages: the permit process, data collection, questionnaires, distributing questionnaires, and conducting interviews (Sani et al., 2020, 2022). The author gets a letter of application for a research permit for Practical Work students from the campus to be given to the Galatians 3 elementary schools so that the author is granted permission to conduct research at the Galatians 3 Elementary School. At the beginning of this permit process, the author requests and fills out a form already available at BAAK to participate in the Practical Work Lecture activities. Then the author asked for a reply letter from the Galatian 3 elementary school that the school invited the author to conduct research at Galatian 3 Elementary School. This reply letter is given to the author to be handed back to BAAK. The school allowed the authors to research at Galatian 3 Elementary School within four months. Some of these processes can see in the flowchart in **figure 2** below.

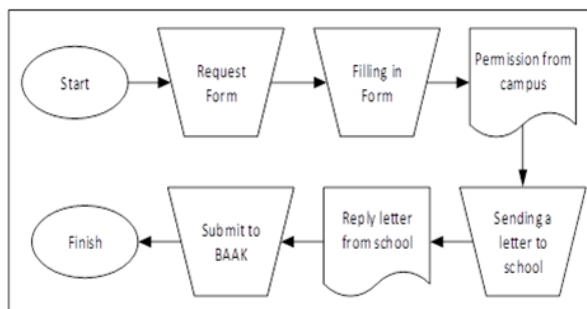

Figure 2 Permit Process Flowchart

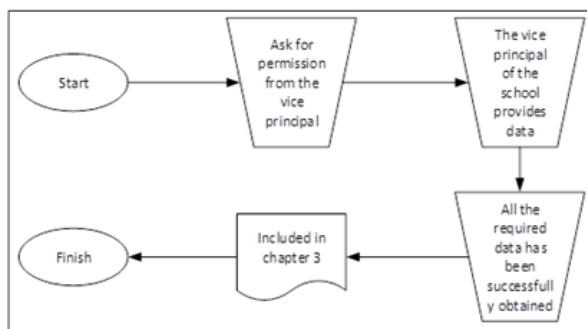

Figure 3 Data Retrieval Process Flowchart

The process of collecting data starts with the author asking permission from the Wakasek to ask for the data needed by the author, and then the

Wakasek provides the data. After the author gets these data,

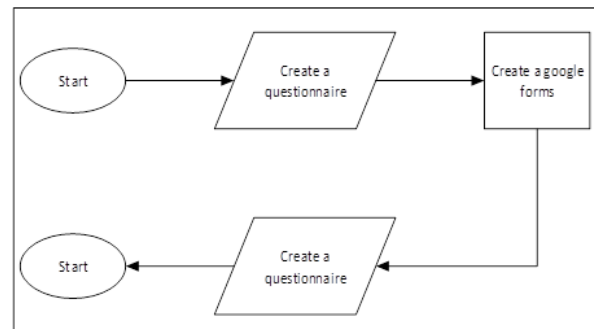

Figure 4 Flowchart of Questionnaire Making

In the process of making a questionnaire, starting from the author make a questionnaire with as many as 20 questions made in the form of a Google Form

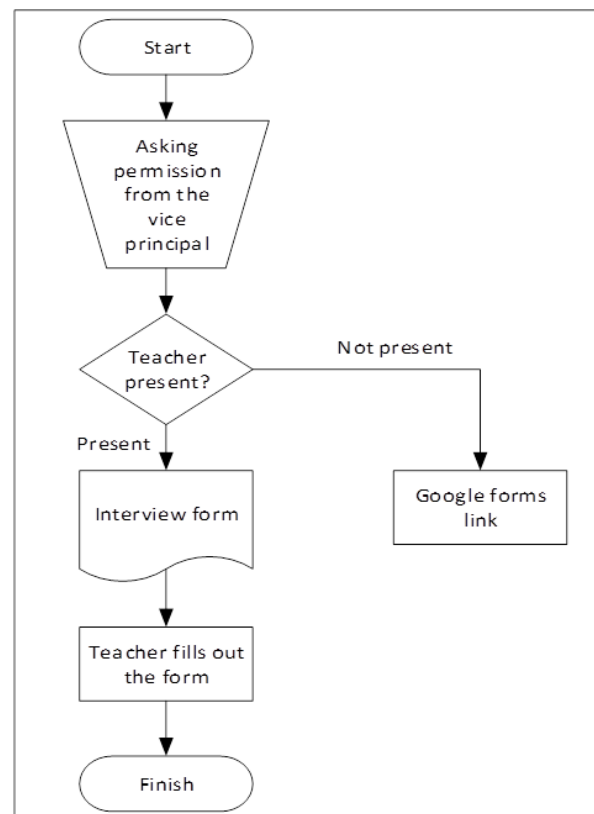

Figure 5 Flowchart of Questionnaire Division

The questionnaire process starts with asking permission from the vice principal to distribute the questionnaire link to elementary school students in grades 1-6. The author gives the questionnaire link to the vice principal. Then the vice principal shares the link with the teacher in grades 1-6, then the teacher in grades 1-6 shares the link with his students and the students fill out the questionnaire.

Moreover, the author's next task is periodically checking the questionnaire results.

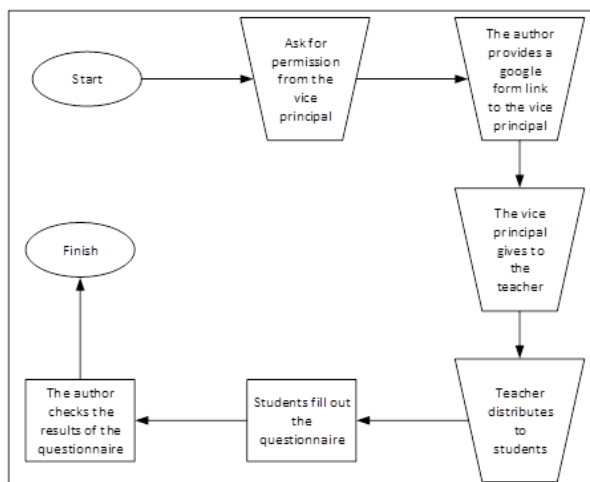

Figure 6 Interview Process Flowchart

The interview process starts with the author asking permission for the vice principal to interview teachers in grades 1-6. The author shares the interview form directly if the teacher is at school (Kurniasi et al., 2020). Meanwhile, if the teacher is not current at school, the author provides an interview link through a Google Form. After that, the teacher fills out the interview form

Data Collection Techniques, Instruments, and Data

TAM Method Indicators

Based on variables from the TAM method used in making questionnaire questions about the use of Google Form to conduct a Daily Assessment distributed to students in grades 1-6 of Galatian 3 Elementary School, there are several indicators adjusted to the questionnaire questions regarding Perceived Ease of Use, Perceived Usefulness, Attitude Toward Using, Attitude Toward Using, and Behavioral Intention to Use. Each of these variables has its indicators, which are described in table 2 below:

Table 2. TAM Method Indicators

Variable	Indicator	
Perceived Ease of Use (PEU)	PEU1	Easy to use
	PEU2	Very helpful
	PEU3	Easy to remember
	PEU4	It can be done anywhere
	PEU5	It does not require much effort
Perceived Usefulness (PU)	PU1	Help facilitate
	PU2	Very helpful
	PU3	Increase productivity

Variable	Indicator	
Attitude Toward Using (ATU)	PU4	Feel Faster
	PU5	Improve the performance
	ATU1	Like to use
	ATU2	Enthusiasm in using
	ATU3	Can be done independently
Behavioral Intention to Use (BIU)	ATU4	Feel bored
	ATU5	Feeling happy
	BIU1	Will use continuously
	BIU2	Intend to continue to use
	BIU3	Wanting to access other systems

The following is the test of the questionnaire results on students in grades 1-6 of Galatia 3 Elementary School, totaling 77 students, tested with four tam method variables to determine whether the use of Google Form as a medium for daily assessment has been accepted or not by users, which described on table 3 below.

Table 3. Overall Results of Questionnaire Calculations using the TAM Method

No	Variable	Average	Criteria
1	Perceived Ease of Use	86,49%	Excellent
2	Perceived Usefulness	84,99%	Excellent
3	Attitude Toward Using	78,75%	Good
4	Behavioral Intention to Use	75,41%	Good
TOTAL		325,64%	
AVERAGE		81,41% (Good)	

Based on the results above, it can be seen that the average respondent's answer score from 5 questions perceived user convenience. The result obtained was 86.49% which is classified as "Excellent." It shows that the Daily Assessment using Google Forms is quite good.

RESULTS AND DISCUSSION

Hypothesis Test Between Variables

In order to ascertain the link between two variables, hypothesis testing is used. Figure 7 below illustrates the size of the relationship between these variables as a percentage.

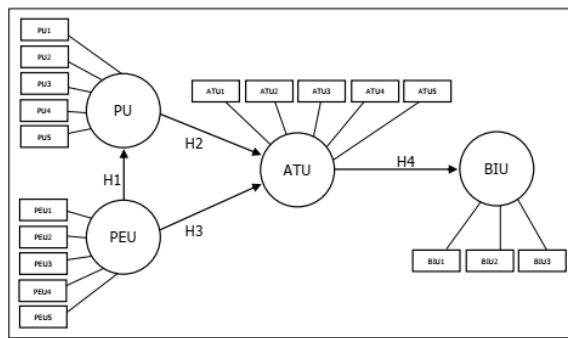

Figure 7 relationships between Variables

Based on the picture above, the author took a hypothesis in the study, namely:

- 1) H1: Is there a relationship between the perceived ease of use variable and perceived usefulness?
- 2) H2: Is there a relationship between the perceived usefulness variable and the attitude toward using?
- 3) H3: Is there a relationship between the perceived ease of use variable and the Attitude Toward Using?
- 4) H4: Is there a relationship between the attitude toward using a variable and the behavioral intention to use it?

Table 4. Hypothesis Test Results

Hypothesis	Significance	R Square
H1	0,00	0,518 (51,8%)
H2	0,00	0,502 (50,2%)
H3	0,00	0,272 (27,2%)
H4	0,00	0,441 (44,1%)

It can be concluded that the first hypothesis has a relationship between the Perceived Ease of Use variable and perceived usefulness with a significance value of 0.00 (<0.05), whose relationship percentage is 51.8%. The two variables have a relationship because the Daily Assessment using Google Forms is very helpful and easy to use to improve student's performance and productivity in learning. In addition, the steps to fill out the Google Form to do the Daily Assessment questions are easy to remember, do not require hard effort, and can be done anywhere. Therefore, students feel that it is faster to do the Daily Assessment, and Google Form helps facilitate online learning for students.

The second hypothesis is the relationship between the perceived usefulness variable and the Attitude Toward Using with a significance value of 0.00 (<0.05), whose relationship percentage is 50.2%. The two variables have a relationship because Google Form helps help to facilitate online learning, so students feel happy and enthusiastic about using Google Forms for online learning.

The third hypothesis is the relationship between the Perceived Ease of Use variable and the Attitude Toward Using with a significance value of 0.00 (<0.05), whose relationship percentage is 27.2%. These two variables have a relationship because students do not need much effort to do the Daily Assessment questions on the Google Form and the steps are easy to remember. Therefore, students can do it independently and like to use Google Forms in online learning. However, the percentage of the relationship between these two variables is the lowest compared to the percentage of relationships of other variables, and this may be because some students feel bored using Google Forms in online learning.

The fourth hypothesis is the relationship between the attitude toward using the variable and the behavioral intention to use it with a significance value of 0.00 (<0.05), whose relationship percentage is 44.1%. These two variables have a relationship because students like to use Google Forms in online learning, so students intend to continue using Google Forms to support the learning process

CONCLUSIONS AND SUGGESTIONS

Conclusion

The conclusions from the results of the questionnaire obtained are as follows: Based on testing using the SPSS application, in the validity test, two questions were eliminated, namely BIU4 and BIU5, because they had a significance value of > 0.05 , namely 0.36 and 0.84 so that the two questions are not processed further from valid items, a reliability test was then carried out, and Cronbach's Alpha results were obtained above 0.7 which means that the questionnaire filled out by respondents had a good level of consistency. From the results of the questionnaire that the author got to find out the attitude of student admissions towards using Google Forms in conducting a Daily Assessment, the author got an average result of 81.41%, which is relatively good. The average result is taken from the four variables of the TAM method. One variable has a connection with the results of hypothesis tests using the SPSS application (Hasyim & Listiawan, 2014). The relationship between the perceived ease of use variables with perceived usefulness was 51.8%, perceived usefulness with attitude toward using was 50.2%, perceived ease of use with attitude toward using was 27.2%, and attitude toward using with the behavioral intention to use was 44.1%. Responses from teachers and students regarding Google Forms are very effective despite shortcomings. For example, teachers cannot directly monitor the results of children's work.

Suggestion

The advice from the author regarding the research that the author conducted on Daily assessments using Google Forms in online learning at SD Galatia 3 is that In conducting Daily Assessments using Google Forms, teachers should use additional applications such as Zoom or Google Meet to monitor children's work directly. Teachers should brief parents, especially in grades 1-3, to get their children used to being independent in doing Daily Assessments through Google Forms so that they are purely the result of children's work. In the validity test, there are two invalid questions. In this study, there are still two invalid questions. The statement is retested.

Acknowledgments

Researchers would like to express their gratitude to the Ministry of Education and Culture, DRPM, and LLDIKTI region 3 for financing the Novice Lecturer Research grant for the fiscal year 2022 for the 2022 implementation year, with contract number 403 / LL3 / AK. 04/VI/2022, as well as STMIK Widuri, who has facilitated lecturers to carry out and participate in activities in the PDP scheme through BIMA.

REFERENCES

- Ayuni, D., Marini, T., Fauziddin, M., & Pahrul, Y. (2020). Kesiapan Guru TK Menghadapi Pembelajaran Daring Masa Pandemi Covid-19. *Jurnal Obsesi: Jurnal Pendidikan Anak Usia Dini*, 5(1), 414. <https://doi.org/10.31004/obsesi.v5i1.579>
- Baety, D. N., & Munandar, D. R. (2021). Analisis efektifitas pembelajaran daring dalam menghadapi wabah pandemi covid-19. *EDUKATIF: Jurnal Ilmu Pendidikan*, 3(3), 880–989.
- Darna, N., & Herlina, E. (2018). Memilih Metode Penelitian Yang Tepat: Bagi Penelitian Bidang Ilmu Manajemen. *Jurnal Ekologi Ilmu Manajemen*, 5(1), 287–292.
- Erawati, I., Darwis, M., & Nasrullah, M. (2017). Efektivitas Kinerja Pegawai pada Kantor Kecamatan Pallangga Kabupaten Gowa. *Jurnal Office*, 3(1), 13–18.
- Fatmawati, E. (2015). Technology Acceptance Model (TAM) untuk Menganalisis Sistem Informasi Perpustakaan. *Iqra': Jurnal Perpustakaan Dan Informasi*, 9(1), 1–13.
- Handarini, O. I., & Wulandari, S. S. (2020). Pembelajaran Daring Sebagai Upaya Study From Home (SFH). *Jurnal Pendidikan Administrasi Perkantoran (JPAP)*, 8(3), 465–503.
- Hasyim, M., & Listiawan, T. (2014). Penerapan Aplikasi IBM SPSS Untuk Analisis Data Bagi Pengajar Pondok Hidayatul Muftadi'in Ngunut Tulungagung Demi Meningkatkan Kualitas Pembelajaran dan Kreativitas Karya Ilmiah Guru. *Jurnal Pengabdian Kepada Masyarakat*, 2(1), 28–35.
- Kurniasi, E. R., Farisma, S., & Hartati, S. (2020). Analisis Soal Ulangan Harian Matematika SMA Negeri 2 Sungaiselan Kelas XI MIPA 1. *Wilangan: Jurnal Inovasi Dan Riset Pendidikan Matematika*, 1(1), 106–113.
- Mulatsih, B. (2020). Penerapan Aplikasi Google Classroom, Google Form, Dan Quizizz Dalam Pembelajaran Kimia Di Masa Pandemi Covid-19 Application of Google Classroom, Google Form and Quizizz in Chemical Learning During the Covid-19 Pandemic. *Jurnal Karya Ilmiah Guru*, 5(1), 19–35.
- Munawaroh, R. Z., Prastowo, A., & Nurjanah, M. (2021). Efektivitas Penilaian Pembelajaran Menggunakan Google Form pada Pembelajaran Daring. *JISIP (Jurnal Ilmu Sosial Dan Pendidikan)*, 5(3). <https://doi.org/10.36312/jisip.v5i3.2152>
- Rijali, A. (2018). Analisis Data Kualitatif Ahmad Rijali UIN Antasari Banjarmasin. 17 (33), 81–95. E-ISSN.
- Sani, A., Aisyah, S., Budiyantara, A., Doharma, R., Hindardjo, A., & Frieyadie, F. (2022). Readiness Technology And Success Model Information Technology In Implementation Between SMEs In Jakarta. *JITK (Jurnal Ilmu Pengetahuan Dan Teknologi Komputer)*, 7(2), 111–118.
- Sani, A., Husain, T., Budiyantara, A., & Wiliani, N. (2020). Influences of the Environmental Context on the IT Adoption and Technology Acceptance Model (TAM) among SMEs.
- Sani, A., Wibawa, A. P., Pusparini, N. N., Rusyid, A., & Hindardjo, A. (2021). The Effect Of Student Behavior On The Use Of Campus Journals By Adopting The TAM Method. *JITK (Jurnal Ilmu Pengetahuan Dan Teknologi Komputer)*, 6(2), 187–194.