Enhancing Performance of Low-Cost Sensors Using an Infant Care Usecase

Leah¹, Khushi Gupta², Perpetua Wagio³

United States International University Africa

lmutanu@usiu.ac.ke, khushigupta2712@gmail.com, pwagio@usiu.ac.ke

Article Info

Article history:

Received Jun 24, 2022

Revised Jul 14, 2022

Accepted Aug 25, 2022

Keyword:

Enhancing Sensors

Low cost Sensors

IoT in Healthcare

ABSTRACT

The drive toward citizen observatories, remote monitoring, and early warning systems has resulted in numerous Internet of things (IoT) innovations. However, the affordability and availability of these solutions challenge their sustainability in areas where they are needed the most. While low-cost sensors address this challenge, their reliability is often questionable. In this respect, this study set out to evaluate techniques that can enhance the efficiency of low-cost sensors in a bid to identify ways of developing sustainable IoT solutions. Experiments conducted using an infant postnatal care prototype demonstrates the potential of the identified techniques. The results showed that sensor calibration, configuration, fabrication fusion, and improvising techniques have the potential to enhance the quality of low-cost sensors. Future work in this area will scale the solution to other use cases.

© This work is licensed under a Creative Commons Attribution-ShareAlike 4.0 International License.

Corresponding Author:

Leah

United States International University Africa

Paul T. Zeleza, Nairobi, Kenya

Email: lmutanu@usiu.ac.ke

1. INTRODUCTION

The growing awareness of opportunities presented by the Internet of Things (IoT) Technology in lifestyle improvement has led to heightened demand for this technology in areas such as healthcare [1]. The pressing goal for IoT technology is increased access for citizens everywhere for crowdsourcing applications to fulfill their promise. The economic costs associated present significant challenges that should be evaluated, especially for low-income countries [2]. Therefore, research on how this technology can result in low-cost devices is required [3].

A lot of research exists on monitoring air pollution through citizen science using low-cost sensors [4]. However, the Quality of data from low-cost sensors has raised concerns, especially in citizen science applications, where citizens are collecting and interpreting the data [1]. Researchers note that Conventional air quality monitoring systems, such as gas analyzers are costly in terms of installation, maintenance, and computational complexities [5]. Low-cost air quality sensors complement these techniques [6], through careful data processing and network design [7], albeit at the expense of accuracy.

This research, therefore, sets out to identify approaches towards enhancing the performance of low-cost sensors using a health care use case and laboratory-simulated experiments. The objectives of this research, are: (i) applying techniques identified in the literature for optimizing low-cost sensors, (ii) developing an IoT Application using low-cost sensors, and (iii) evaluating the

techniques used for enhancing low-cost sensors through laboratory-simulated experiments. The rest of the paper is structured as follows: Section 2 reviews related literature; section 3 describes the prototype design and processes; section 4 presents the results and the paper concludes in Section 5.

2. REVIEW AND RELATED WORK

While investigating sensor performance, Zimmerman, [8] points out that low-cost sensors are sensitive to environmental conditions and pollutant cross-sensitivities, which affect their performance. Despite technical limitations, low-cost sensors provide indicative measurements such as air quality, which are valuable to local communities [9]. While they do not eliminate the need for stronger investment in high-quality monitoring, they create opportunities for civic engagement, in collaboration with local experts who are well-equipped to ensure the data collected is interpreted accurately for the public. A study on Efficient IoT-based sensors observed that Cost reduction could be achieved by exploiting the abilities of the technologies in question [10]. The literature reviewed in this study revealed various techniques that researchers have adopted to optimize low-cost sensors for enhanced performance.

2.1 Sensor Calibration

Sensor Calibration is a process used to obtain the conditional distribution of an unknown value x that characterizes an observation y made by a sensor. This is the probability distribution to be assigned to the (unknown) “true” value, x , given the observation, y , and the instrument parameters, θ , which include parameters describing the noise in the measurement [11]. Sensor calibrations can reduce noise that originates from external factors such as temperature and humidity, which influence the sensor measurement of interest. A study to determine identifying factors that affect the data quality of low-cost IoT sensors in environmental monitoring networks used Linear Regression, and ANN to calibrate cairclipO3/NO2 and cairclipNO2 sensors [4]. Findings from the study showed that calibrating improved measurement. A different study involving tri-axis tactile sensors for monitoring slip force and contact angle detection [12], calibrated force output from the measured inductances. The results obtained indicated a good match between the calibrated tactile sensor and the equivalent commercial level sensor.

2.2 Sensor Configuration

Sensor Configuration is another way of improving the performance of low-cost sensors as demonstrated in the work of Chowdhury [13]. The study shows how a low-cost braille embosser was configured using braille translation software to print text using a normal printer. They achieved this by configuring a port to send the specific data to the master Bluetooth module via Arduino mega and ended up with a low-cost braille embosser that was cheaper than existing embossers were. A different study on Solar Tracking systems design noted that conventional tracking systems demand a larger number of tracking units, for the same power capacity of the system, [14]. In their work, they use a master-slave control configuration, and the required tracking information is sent to all of the slave trackers using wireless communication. The result was a low-cost control tracking system achieved by reconfiguring the way the sensors operated. These studies show that the configuration of low-cost sensors presents opportunities to accommodate the loss of efficiency imposed by their poor quality, hence enhancing their performance.

2.3 Multisensory Data Fusion

Other studies adopted a Multisensory data-fusion approach. One study [15] demonstrates this strategy by integrating multiple complementary low-cost sensors to estimate vehicle motion-status information. A separate study [16] also used a data fusion technique to combine sensor network data with an air quality model, which simulates the spatial patterns of pollutants. A review of Data fusion techniques [17] observes that data fusion techniques enhance the performance of low-cost sensors by complimenting sensors that fail or moderating erroneous readings.

2.4 Sensor Fabrication

Sensor Fabrication refers to the process of manufacturing or inventing sensors. Noting that the material used to make sensors contributes largely to the costs of the sensor, one study [18] fabricated a pressure sensor based on graphene ink and the network structure of textiles using a simple and low-cost dip-coating method. While in these studies the goal has cost reduction, fabrication also enhances performance. For example, one study demonstrates the fabrication of low-cost miniaturized microbial fuel sensors to produce the shortest response time compared to their macroscale counterparts and a broader linear range [19]. A different study fabricated a glucose level sensor, yielding an excellent amperometric response to glucose detection, high sensitivity, and a short response time [20].

2.5 Improvising Sensors

The Fabrication of sensors can be a costly and challenging affair in terms of effort, usability, and performance. In such cases, the improvising of Low-cost sensors presents a suitable alternative to high-cost sensors. As an example, one study shows how [18] a pressure sensor is used in innovative ways such as wrist pulse detection, finger press detection, and walking state monitoring. Ultrasonic sensors are used primarily as proximity sensors in assistive or robotics [21] mobility solutions. Recent studies however demonstrate how the same sensors can measure the height of objects such as crops on the farm [22] therefore informing farming activities such as pruning time, harvest time, or germination problems. Similarly, Doppler radar sensors used in weather forecasts to predict the onset of precipitation [23, 24], now find applications in heart rate detection [25, 26]. Combining sensors to find applications in new ways is another way of improvising sensors. These studies highlight the significance of improvising monitoring using low-cost sensors where low-cost alternatives do not exist.

3. SOLUTION DESIGN

To the best of our knowledge, very little research exists describing different approaches used to optimize low-cost sensors. This study provides early discussion in this area through results extracted from a health monitoring use case.

Despite significant progress in reducing child mortality rates globally, the death rate is still unacceptably high, with an estimated 5.2million deaths of children under age five occurring last year [27]. According to the World Health Organization [28], the major cause of neonatal deaths worldwide is infections (36%), pre-term complications (28%), and birth asphyxia (23%), all of which are preventable with timely intervention. Global guidelines on postnatal care for mothers and newborns require at least four postnatal checkups in the first 6 weeks of a baby's life. A requirement that is challenging to fulfill, especially in marginalized communities where parents cannot afford to make routine hospital visits, lack the knowledge required to detect these danger signs, and live in areas where health centers are scarcely distributed. We set out to develop a low-cost solution that remotely allows a child caregiver or community health worker to conduct infant screening at the child's home. Typical growth-monitoring parameters include height, weight, brain development, and motor skills milestones, while health monitoring calls for the examination of temperature, skin condition, breathing rate, and heart rate. While some devices exist to take these measurements such as the digital weighing scales, they are often costly, not portable, and require expert skills. The developed solution enables health care providers, caregivers, or cloud server analytics algorithms to receive these parameters for decision making as illustrated in Figure 1. These parameters are analyzed and alerts are generated for early intervention.

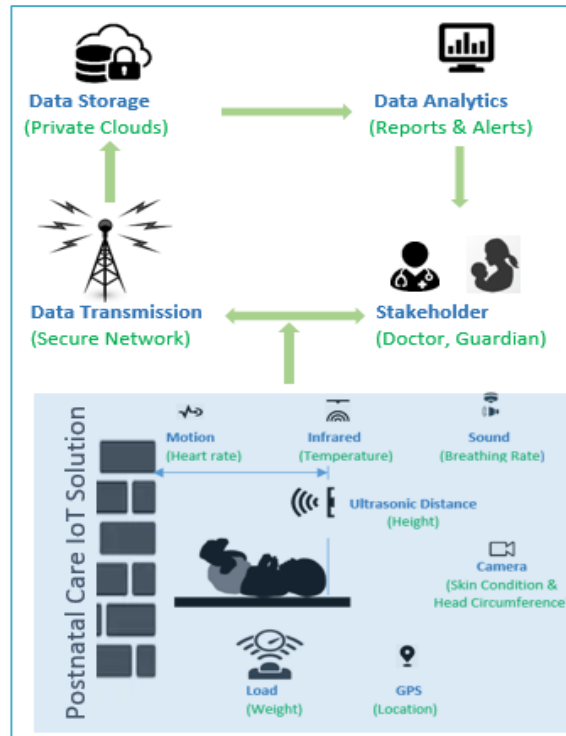

Figure 1. Remote Infant Healthcare Model

Given the critical nature of health decisions, measurements call for very high accuracy levels, often found in high-quality sensors. This renders the solution inaccessible to most users in marginalized communities where the solution is required. This study presents novel approaches to enhancing the quality of low-cost sensors as a solution for affordable remote patient monitoring solutions using an infant post-natal care solution. To investigate optimization opportunities, we identified low-cost sensors that can monitor weight, skin condition, temperature, brain development, and fine motor skills. Factors such as affordability and availability informed the choice of sensors; therefore, mass-produced low-cost sensors were used. In this section, we examine the approaches adopted in this study to optimize the performance of low-cost sensors.

3.1 Calibration of a low-cost weight sensor

To measure the baby's weight we used Strain gauge load cells, which convert a load into electrical signals depending on the resistances experienced on each strain gauge. The circuit diagram in Figure 2 shows how the load cell interfaces with the Arduino using the HX711 Load cell amplifier module.

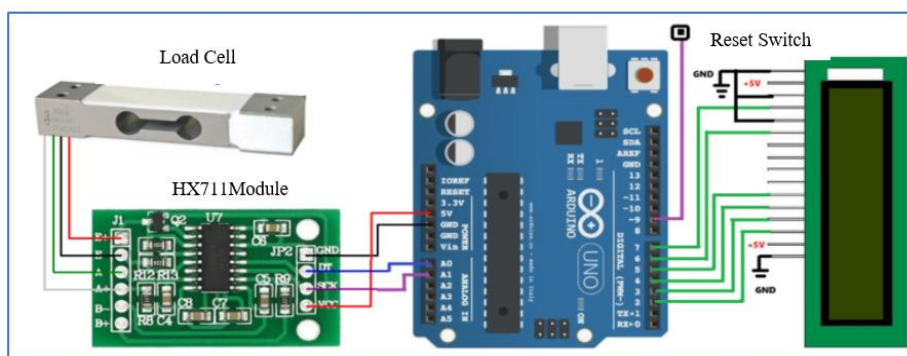

Figure 2. Load Cell Interfacing

For calibration purposes, the HX711 library assumes a linear relationship of load sensor output to weight. The standard formula for a line $Y = MX + B$ is used, where M is the slope of the

line and B is the intercept. The values M and B represent the required HX711 library SCALE and OFFSET respectively. Given two parameters (X, Y) the slope and intercept of the line were calculated using Eqn. (1) and (2)

$$M = \frac{Y_2 - Y_1}{X_2 - X_1} \quad (1)$$

$$B = Y - MX \quad (2)$$

We calculated M and B using the 50 and 100 grams weights, followed by 100 and 200 grams weights. The results obtained gave M = 104 and B = 103229, which were used to set the scale and offset for calibration. Calibrations done using weights of 50, 100, 200, 400, and 1000 grams yielded the output readings given in Table 1.

Table 1. Calibration Output Readings for various weights

X Weight (grams)	Y Average reading
50	108429
100	113629
200	124029
400	144829
1000	207229

3.2 Configuration of a low-cost Camera module

For purposes of detecting the infant's skin condition as well as the registration number on a card, a camera was required to take images. We used the low-cost OV7670 Arduino Camera Sensor, which has a 0.3 megapixel CMOS color camera module powered by a single +3.3V power supply. We required smaller images for efficient transmission and storage, achieved by compressing the images or sending smaller images. We opted for the latter by re-configuring the camera settings to take images with a lower resolution. The resolution is selected by changing the value in the cameraImg() function as shown in the code snippet in Figure 3.

```
static void captureImg(uint16_t wg, uint16_t hg){
    uint16_t y, x;

    StringPgm(PSTR("ARDY*"));

    while (!(PIND & 8)); //wait for high
    while ((PIND & 8)); //wait for low

    y = hg;
    while (y--){
        x = wg;
        //while (!(PIND & 256)); //wait for high
        while (x--){
            while ((PIND & 4)); //wait for low
            UDRO = (PINC & 15) | (PIND & 240);
            while (!(UCSROA & (1 << UDRE0))); //wait for byte to transmit
            while (!(PIND & 4)); //wait for high
            while ((PIND & 4)); //wait for low
            while (!(PIND & 4)); //wait for high
        }
        // while ((PIND & 256)); //wait for low
    }
    _delay_ms(100);
}

void loop(){
    captureImg(320, 240);
}
```

Figure 3. Configuring the resolution of the camera module

3.3 Data Fusion of low-cost temperature sensors

One of the parameters useful when monitoring a baby is the baby's or the environment's temperature. Due to the accuracy challenges presented by low-cost sensors, we set out to investigate whether the fusion of low-cost sensors can enhance their performance. To achieve this we set up two low-cost sensors, a DHT 11 Sensor and a DS18B20 Sensor. To evaluate the performance,

measurements from both sensors are taken and the mean computed. As a control, measurements taken by a more accurate higher cost infrared (IR) sensor, the MLX 90614 Sensor, are compared. The fused sensor setup is illustrated in Figure 4.

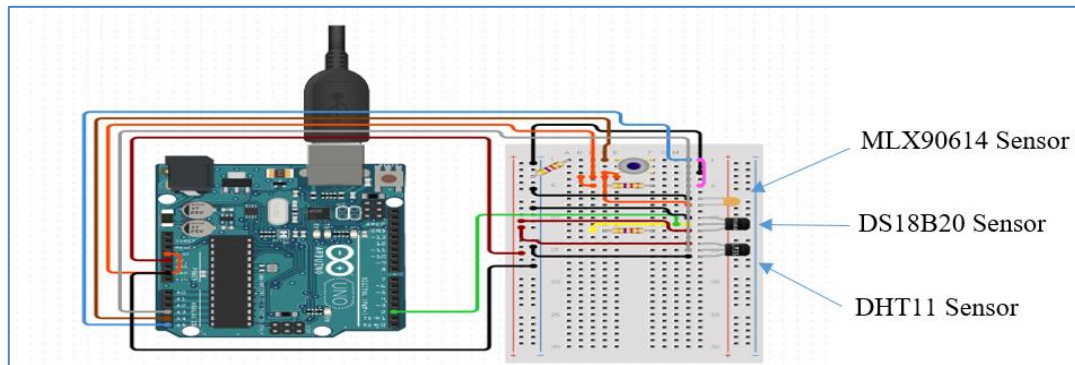

Figure 4. Fused temperature sensors

3.4 Fabrication of a low-cost grip sensor

One of the aspects monitored to gauge a baby's fine motor skill is the movement of the hands and fingers to grasp and manipulate objects. Fine motor skills indicate how the baby coordinates thoughts and actions [29]. From the age of three months, babies should be able to hold small objects. Flexible force resistive sensors evaluate the force applied when a hand grasps an object [30]. While these sensors offer low costs, the mechanical properties of the rubbery material utilized in their manufacturing limit their application due to slow response speeds. To address this limitation we set out to fabricate a low-cost sensor with a less resistive material. Typically, the grip on an object translates to pressure applied on an object. Therefore, the sensor needs to detect the presence or absence of pressure, without emphasis on the amount of force applied.

The fabrication of pressure sensors uses various principles classified according to the sensing element used such as piezoresistive, piezoelectric, or capacitive. Capacitive pressure sensors offer linear output compared to piezoresistive and piezoelectric pressure sensors, hence their choice for this study. We fabricated a capacitive pressure sensor using two aluminum foil sheets with an insulator between them, as shown in the circuit diagram in Figure 5. The application of pressure to the sheets increases the capacitance. The sensor only provides scalar indicators, but these are adequate for grip detection.

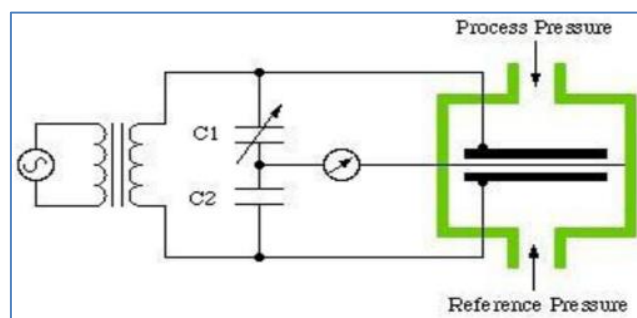

Figure 5. Capacitive pressure sensor circuit diagram (Source, [31])

Eqn. (3) gives the capacitance of a parallel plate capacitor, where A is the area of the plates, d is the distance between the plates, and the dielectric constant ϵ depends on the material used. The capacitance will increase the larger the plates are and the closer they are to each other. The readings obtained are therefore relative to the applied force.

$$C = \frac{\epsilon A}{d} \quad (3)$$

3.5 Improvising Brain Development Sensors

For infants and children below the age of three, monitoring brain development forms part of the growth development assessment. The measurement of Brainwave patterns is one way of assessing the brain-growth. These patterns index a form of brain activity that reflects changes in the functioning of the brain. Some methods of monitoring this brain activity include Magnetoencephalography (MEG), Functional magnetic resonance imaging (fMRI), frequency-domain near-infrared spectroscopy (FD-NIRS), and electroencephalogram (EEG). These methods however make use of high-cost sensors and require expert operation skills.

A more traditional approach for assessing brain growth is through the measurement of a baby's head circumference. Monitoring an infant's head circumference can reveal whether the infant's brain is growing and developing normally [32]. Head circumference or OFC (occipital frontal circumference) is measured over the most prominent part on the back of the head (occiput) and just above the eyebrows (supraorbital ridges). The process can be automated using 3D surface imaging devices but this can also prove to be very costly. We made use of the camera module to perform this measurement by taking an image of the baby's head from the top when the baby is lying down using the Raspberry Camera. To ensure that the largest circumference of the head is taken (OFC), the tip of the nose and ears have to be simultaneously visible. These images are transmitted to a server, where Machine learning techniques are applied for image processing and object detection alongside a reference object for circumference calculations.

Calculating the head circumference from images called for several image-processing steps namely resizing, noise removal, and edge detection. Camera calibration improves the accuracy of the results by addressing the camera's extrinsic parameters (such as rotation and translation) and intrinsic parameters (such as focal length and optical center). For this experiment, we used the checkerboard camera calibration approach [33] and OpenCV chessboard calibration library to calibrate the camera used and generate undistorted images from any image taken with the camera. The results of each process illustrated in Figure 6, belong to a sample image and reference object.

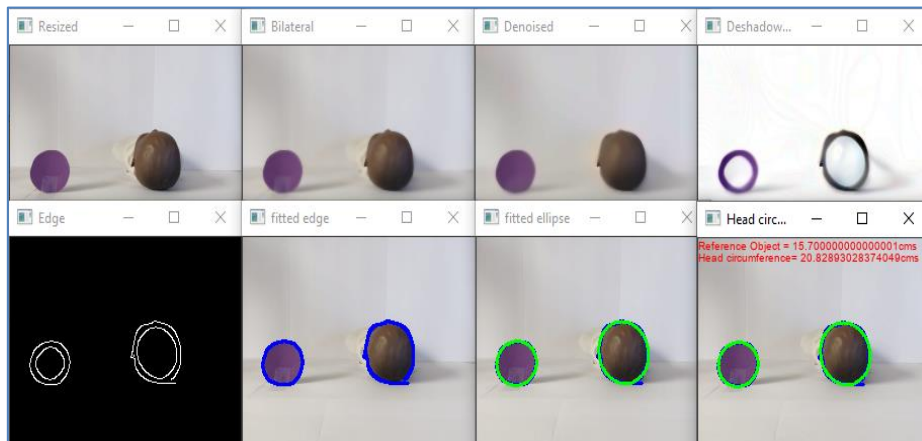

Figure 6. Head Circumference Image processing steps

Following the object detection, an ellipse fitted in the resultant images helps in estimating the head circumference through perimeter calculations. The reference object helps in obtaining the pixels per metric ratio using the formula provided in Eqn. (4) as described in the work of [34]. This ratio measures the number of pixels per given metric, thus taking care of varying image distances or camera focal aspects.

$$\text{Pixels Per Metric} = \frac{\text{Object Width}}{\text{Reference Width}} \quad (4)$$

This ratio determines the head's width and height from the ellipses contour and the perimeter obtained using Ramanujan's approximation formula of finding the perimeter of an ellipse [35] given in Eqn. (5). In the equation a and b represent the height and width of the ellipse respectively.

$$Circ = \pi[3(a + b) - \sqrt{(3a + b)(a + 3b)}] \quad (5)$$

It is worth noting that the presence of external objects needs to be minimized to reduce noise distortions.

4. EXPERIMENTAL RESULTS AND DISCUSSION

4.1 Performance of low-cost Calibrated Sensors

The results from experiments showed that calibrated load cells can measure weights within acceptable ranges. Results from the working prototype on different weights gave an average accuracy of 99.29%, an indication that the calibrated low-cost weight sensor is accurate as tabulated in Table 2.

Table 2. Performance of the calibrated weight sensor













Test	Actual Weight	Load Sensor Weight	Accuracy
1	100grams	99.26grams	99.26%
2	200grams	198.52grams	99.26%
3	400grams	398.23grams	99.55%
4	800grams	794.15grams	99.26%
5	1000grams	992.60grams	99.26%
6	1200grams	1191.52grams	99.29%
7	1400grams	1390.83grams	99.34%
8	1600grams	1587.23grams	99.20%
9	1800grams	1787.15grams	99.28%
10	2000grams	1985.26grams	99.26%
Average			99.29%

One notable challenge was the increase in the fluctuation as we increased the load-cell capacity, a problem attributed to the Supply voltage. By adding a voltage regulator for HX711 we resolved the problem.

4.2 Performance of low-cost Configured sensors

To test the performance of our low-cost configured camera, we trained a neural network model to detect the presence or absence of skin rashes and used a high-cost Raspberry pi camera to capture high-resolution images for comparison. A Raspberry pi camera costs seven times more than the OV7670 Camera and has a resolution of up to 1024x768ppi. The configured OV7670 Camera has a maximum resolution of 640x480ppi. To make it work well with our microcontroller, we configured it to a lower resolution of 320x240ppi to improve processing speeds. The results presented in Table 3 show the accuracy levels obtained from four high-resolution images retrieved from a publicly available dataset [36] and the comparisons from both the high-cost and low-cost camera modules. For purposes of obtaining comparable results in this experiment, the Raspberry pi camera resolution was lowered to 320x240ppi.

Table 3. Performance of calibrated low-cost sensors

Original High Resolution Image		Raspberry Pi Camera Image (320x240ppi)		OV7670 Camera Image (320x240ppi)	
	C1~0.91 C2~0.00		C1~0.91 C2~0.01		C1~0.87 C2~0.05
	C1~0.91 C2~0.00		C1~0.91 C2~0.00		C1~0.89 C2~0.01
	C1~0.85 C2~0.15		C1~0.88 C2~0.12		C1~0.84 C2~0.28
	C1~0.00 C2~0.91		C1~0.06 C2~0.90		C1~0.02 C2~0.91

Key: C1 – Rush Class C2 – No Rush Class

The results show that although the images taken by the low-cost camera had a low resolution, the machine learning classifier produced acceptable accuracy levels. Additionally, the results obtained show that the accuracy levels obtained by both the high-cost and low-cost cameras were comparable.

4.3 Performance of low-cost Fused Sensor Data

To investigate performance enhancement due to data fusion, two low-cost sensors are fused (The MLX 90614, DHT 11/22, and DS18B20 Sensors). To assess the performance of the sensors, the deviation of the low-cost sensor readings from the more accurate sensor (Sensor 1) was calculated and charted using a box and whisker chart in the figure. The results show a significant reduction in deviations for the fused data compared to the deviations of the individual sensor readings (Sensor 2 and Sensor 3) as illustrated in Figure 7. This highlights that data fusion is a viable technique for enhancing the performance of low-cost sensors.

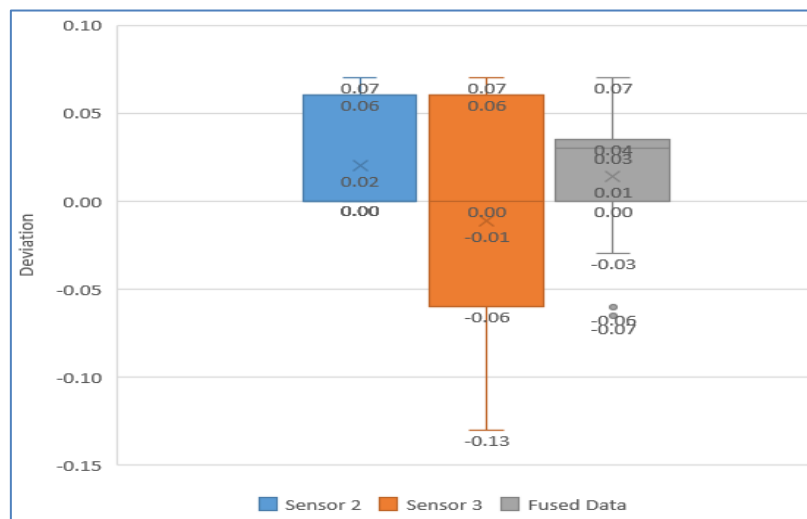

Figure 7. Performance of fused data sensors

4.4 Performance of low-cost Improvised Sensors

To test the accuracy of the calculated head circumference several images were taken for two dolls, and the Mean Absolute Percentage Error (MAPE) error was calculated using Eqn. (6) [37], for each parameter. This method evaluates results by calculating the margin of error from predicted or expected data.

$$MAPE = \frac{\sum \frac{|Expected\ Value - Experimental\ Value|}{Expected\ Value}}{\text{Nnumber of measurements}} \times 100\% \quad (6)$$

To test scalability, dolls of different sizes were used. The results presented in Table 4 show the MAPE error as 2.65% and 2.40% when two dolls with a head circumference of 12.5cm and 38cm respectively were tested. As a novel idea, the concept has numerous potential in infant postnatal care, given the consistency of the results obtained. It provides a contactless option of automating the process of monitoring the head circumference digitally. The use of a reference object of known dimensions also complements the approach by providing a visual verification process for enhanced reliability. Enhanced image processing and noise cancellation techniques reduce the error value further.

Table 4. Head Circumference results

Image Samples	1	2	3	4	5	6	7	8	9	MAPE Error
Circumference. (12.5cm)	21.11	20.93	21.04	20.63	21.01	20.95	20.83	21.16	20.86	2.65%
Circumference. (38cm)	37.26	37.08	36.38	37.21	36.63	37.83	36.95	37.58	37.12	2.40%

4.5 Performance of low-cost Fabricated Sensors

To evaluate the performance of our fabricated sensor we used an object to exert comparable pressure on the fabricated sensor and a force resistive sensor. The object contact area had to be small enough to match the surface area of the Force Resistive Sensor. In this way, we ensured that the reference pressure remained the same for both experiments. The results in Table 5 show that the mean fabricated pressure pad readings are comparable to those obtained from the high-cost Force resistive sensor.

Table 5. Fabricated and Force resistive sensors readings.

	Sensor Readings									Mean
*	1.557	1.05	1.35	1.29	1.46	1.42	1.62	1.43	1.41	1.397
**	1.47	0.66	1.08	1.11	1.20	1.32	1.68	1.75	1.58	1.317

KEY: *. Fabricated Pressure, ** Force Resistive

4.6 Cost advantage of low-cost sensors

In order to appreciate the accessibility advantage offered by low-cost sensors, we analyzed the cost of their high-quality equivalent available in the market during the time of this study. An analysis of the low-cost sensors against their high-cost equivalent at the time of writing this paper, is presented in Table 6. The results show that low-cost sensors offer a significant advantage over the more reliable higher cost sensors. Therefore employing the techniques discussed would make the solution more accessible to economically marginalized users.

Table 6. Comparison of low versus high-cost sensors.

LOW-COST SENSOR	COST (US\$)	HIGH-COST ALTERNATIVES	COST (US\$)
Load Cell and HX711 ADC	9.00	CALT DYLY103 Load Cell Sensor	45
Fabricated Force Sensor	1	FSR402 Force Resistive Sensor	14
DS18B20 temperature sensor	2.00	MLX 90614 Temperature Sensor	17
OV7670 Camera Module	5.00	RPI-CAM-V2 Raspberry pi camera Module	35
OV7670 Camera Module	5.00	EEG Sensor	130
TOTAL	22.00		241

5. CONCLUSION

This study set out to investigate ways of enhancing the performance of low-cost IoT sensors. The affordability and availability of IoT solutions challenge their sustainability in low and middle-income areas, where they are needed the most due to scarce resources. Low-cost mass-produced sensors have a wider circulation in the market compared to specialized high-cost sensors. The results obtained show that the techniques proposed in the literature namely: calibration, configuration, data fusion, improvising, and fabrication enhance the performance of low-cost sensors. This makes the development and testing of the proposed approaches more feasible. We envisage that the study findings will spark further interest in this area and improve on the findings. This study used a single-use case and presented initial results obtained from laboratory experiments. Further research is required to test the proposed solution in the field and use different use cases for further evaluation of its efficacy.

REFERENCES

- [1] [Castell N, Dauge FR, Schneider P, Vogt M, Lerner U, Fishbain B, Broday D, Bartonova A. Can commercial low-cost sensor platforms contribute to air quality monitoring and exposure estimates?. *Environment international*. 2017 Feb 1;99:293-302.
- [2] Memos VA, Minopoulos G, Stergiou KD, Psannis KE. Internet-of-Things-Enabled Infrastructure Against Infectious Diseases. *IEEE Internet of Things Magazine*. 2021 Jul 21;4(2):20-5.
- [3] Manyika J, Chui M, Bisson P, Woetzel J, Dobbs R, Bughin J, Aharon D. *The Internet of Things: Mapping the Value Beyond the Hype*, McKinsey Global Institute, 2015, 131 p. Available (referred 13.1. 2017): <http://www.mckinsey.com>.
- [4] Okafor NU, Alghorani Y, Delaney DT. Improving data quality of low-cost IoT sensors in environmental monitoring networks using data fusion and machine learning approach. *ICT Express*. 2020 Sep 1;6(3):220-8.
- [5] Kokkonis G, Psannis KE, Roumeliotis M, Schonfeld D. Real-time wireless multisensory smart surveillance with 3D-HEVC streams for internet-of-things (IoT). *The Journal of Supercomputing*. 2017 Mar;73(3):1044-62.
- [6] Alhasa KM, Mohd Nadzir MS, Olalekan P, Latif MT, Yusup Y, Iqbal Faruque MR, Ahamad F, Abd. Hamid HH, Aiyub K, Md Ali SH, Khan MF. Calibration model of a low-cost air quality sensor using an adaptive neuro-fuzzy inference system. *Sensors*. 2018 Dec 11;18(12):4380.
- [7] Popoola OA, Carruthers D, Lad C, Bright VB, Mead MI, Stettler ME, Saffell JR, Jones RL. Use of networks of low cost air quality sensors to quantify air quality in urban settings. *Atmospheric Environment*. 2018 Dec 1;194:58-70.
- [8] Zimmerman N, Presto AA, Kumar SP, Gu J, Haurlyuk A, Robinson ES, Robinson AL, Subramanian R. A machine learning calibration model using random forests to improve sensor performance for lower-cost air quality monitoring. *Atmospheric Measurement Techniques*. 2018 Jan 15;11(1):291-313.

- [9] deSouza P, Nthusi V, Klopp JM, Shaw BE, Ho WO, Saffell J, Jones R, Ratti C. Research article A Nairobi experiment in using low cost air quality monitors. *Clean Air Journal*. 2017;27(2):12.
- [10] Plageras AP, Psannis KE, Stergiou C, Wang H, Gupta BB. Efficient IoT-based sensor BIG Data collection–processing and analysis in smart buildings. *Future Generation Computer Systems*. 2018 May 1;82:349-57.
- [11] Williams DE. Low cost sensor networks: how do we know the data are reliable?. *ACS sensors*. 2019 Sep 16;4(10):2558-65.
- [12] Wang H, Kow J, De Boer G, Jones D, Alazmani A, Culmer P. A low-cost, high-performance, soft tri-axis tactile sensor based on eddy-current effect. In *2017 IEEE SENSORS 2017* Oct 29 (pp. 1-3). IEEE.
- [13] Chowdhury D, Haider MZ, Sarkar M, Refat M, Datta K, Fattah SA. An intuitive approach to innovate a low cost Braille embosser. *International Journal of Instrumentation Technology*. 2018;2(1):1-7.
- [14] Burhan M, Oh SJ, Chua KJ, Ng KC. Double lens collimator solar feedback sensor and master slave configuration: Development of compact and low cost two axis solar tracking system for CPV applications. *Solar Energy*. 2016 Nov 1;137:352-63.
- [15] Li X, Xu Q. A reliable fusion positioning strategy for land vehicles in GPS-denied environments based on low-cost sensors. *IEEE Transactions on Industrial Electronics*. 2016 Dec 7;64(4):3205-15.
- [16] Schneider P, Castell N, Vogt M, Dauge FR, Lahoz WA, Bartonova A. Mapping urban air quality in near real-time using observations from low-cost sensors and model information. *Environment international*. 2017 Sep 1;106:234-47.
- [17] Khaleghi B, Khamis A, Karray FO, Razavi SN. Multisensor data fusion: A review of the state-of-the-art. *Information fusion*. 2013 Jan 1;14(1):28-44.
- [18] Fan Y, Zhao H, Wei F, Yang Y, Ren T, Tu H. A facile and cost-effective approach to fabrication of high performance pressure sensor based on graphene-textile network structure. *Progress in Natural Science: Materials International*. 2020 Jun 1;30(3):437-42.
- [19] Xiao N, Wu R, Huang JJ, Selvaganapathy PR. Development of a xurographically fabricated miniaturized low-cost, high-performance microbial fuel cell and its application for sensing biological oxygen demand. *Sensors and Actuators B: Chemical*. 2020 Feb 1;304:127432.
- [20] Xuan X, Yoon HS, Park JY. A wearable electrochemical glucose sensor based on simple and low-cost fabrication supported micro-patterned reduced graphene oxide nanocomposite electrode on flexible substrate. *Biosensors and Bioelectronics*. 2018 Jun 30;109:75-82.
- [21] Cho IJ, Lee HK, Chang SI, Yoon E. Compliant ultrasound proximity sensor for the safe operation of human friendly robots integrated with tactile sensing capability. *Journal of Electrical Engineering and Technology*. 2017;12(1):310-6.
- [22] Yuan W, Li J, Bhatta M, Shi Y, Baenziger PS, Ge Y. Wheat height estimation using LiDAR in comparison to ultrasonic sensor and UAS. *Sensors*. 2018 Nov 2;18(11):3731.
- [23] Khanal AK, Delrieu G, Cazenave F, Boudevillain B. Radar remote sensing of precipitation in high mountains: Detection and characterization of melting layer in the grenoble valley, french Alps. *Atmosphere*. 2019 Dec 6;10(12):784.
- [24] Yang Z, Liu P, Yang Y. Convective/stratiform precipitation classification using ground-based Doppler radar data based on the K-nearest neighbor algorithm. *Remote Sensing*. 2019 Sep 29;11(19):2277.
- [25] Ebrahim MP, Heydari F, Redoute JM, Yuce MR. Accurate heart rate detection from on-body continuous wave radar sensors using wavelet transform. In *2018 IEEE SENSORS 2018* Oct 28 (pp. 1-4). IEEE.
- [26] Petrović VL, Janković MM, Lupšić AV, Mihajlović VR, Popović-Božović JS. High-accuracy real-time monitoring of heart rate variability using 24 GHz continuous-wave Doppler radar. *IEEE Access*. 2019 Jun 6;7:74721-33.
- [27] UNICEF, “Under-five mortality. UNICEF DATA,” <https://data.unicef.org/topic/child-survival/under-five-mortality/>, 2020, September 14, Accessed 8th February 2022.

- [28] WHO, "The WHO Child Growth Standards," <https://www.who.int/childgrowth/standards/>, 2020, Accessed 10th June 2021.
- [29] Veldman SL, Santos R, Jones RA, Sousa-Sá E, Okely AD. Associations between gross motor skills and cognitive development in toddlers. *Early human development*. 2019 May 1;132:39-44.
- [30] Biju SM, Sheikh HZ, Malek MF, Oroumchian F, Bell A. Design of grip strength measuring system using FSR and flex sensors using SVM algorithm. *International Journal of Artificial Intelligence*. 2021;10(3):
- [31] Razak AH, Zayegh A, Begg RK, Wahab Y. Foot plantar pressure measurement system: A review. *Sensors*. 2012 Jul 23;12(7):9884-912.
- [32] Firmansyah R, Widodo A, Romadhon AD, Hudha MS, Saputra PP, Lestari NA. The prototype of infant incubator monitoring system based on the internet of things using NodeMCU ESP8266. *InJournal of Physics: Conference Series 2019 Feb 1 (Vol. 1171, No. 1, p. 012015)*. IOP Publishing.
- [33] Placht S, Fürsattel P, Mengue EA, Hofmann H, Schaller C, Balda M, Angelopoulou E. Rochade: Robust checkerboard advanced detection for camera calibration. *InEuropean conference on computer vision 2014 Sep 6 (pp. 766-779)*. Springer, Cham.
- [34] Deplomo BN, Balbin JR. Categorizing Of Allium Sativum Based On The Philippines National Standard And Asian Standard Using Pixel Per Metric Ratio And Blob Detection Methods. *PalArch's Journal of Archaeology of Egypt/Egyptology*. 2020 Nov 3;17(9):3927-41.
- [35] Villarino MB. Ramanujan's Perimeter of an Ellipse. *arXiv preprint math/0506384*. 2005 Jun 20.
- [36] DermNet, 2021, "Skin conditions in children | DermNet NZ. [online] [Dermnetnz.org](https://dermnetnz.org). Available at: "<https://dermnetnz.org/topics/skin-conditions-in-children/>", Accessed 1st March 2021.
- [37] Khair U, Fahmi H, Al Hakim S, Rahim R. Forecasting error calculation with mean absolute deviation and mean absolute percentage error. *InJournal of Physics: Conference Series 2017 Dec 1 (Vol. 930, No. 1, p. 012002)*. IOP Publishing.