



Research Article

Energy Efficiency and Greenhouse Gas Emissions Reduction Through Electrification Program at Tanjung Enim Mine Business Unit of PT Bukit Asam (Persero) Tbk.

Iko Gusman¹, Pramudita Triatmojo¹, Peni Rostiarti¹, Bima Arifiyanto¹

*1PT. BUKIT ASAM (Persero) Tbk. - Unit Pertambangan Tanjung Enim
Jalan Parigi No.1-A Kecamatan Lawang Kidul, Kabupaten Muara Enim,
Sumatera Selatan - Indonesia
igusman@bukitasam.co.id*

ABSTRACT

Current global economic conditions have made the coal prices become uncertain. PT Bukit Asam (PTBA) has taken corporate action by improving operational efficiency, cost control; develop coal diversification product and also optimization in the mining operation. One of the operational efficiency programs for cost control in mining operation system is the Electrification Program. This program changed mining operations previously dominated by fuel-based mining system transformed into an electricity-based mining system for an electric shovel continue with the conventional truck. Implementation of Mining Systems with electric-based mining equipment divided into several stages for short-term and long-term targets. Electrification program consist of 7 Units Electric Shovel (PC3000-6E) and 40 Units Rigid DT (Belaz75135) with target 20 Million BCM in 2017 located in Banko West Mine. PTBA through the electrification program has succeeded in reducing energy consumption by 333,861.74 Joule/Years and reducing greenhouse gas emissions by 15,058.49 Ton CO₂e/Year. Electrification program has successfully contributed for environmental sustainability by reducing energy consumption and greenhouse gas emissions in accordance with the vision of PTBA into a world-class energy company that cares about the environment.

Keywords: Electrification, Mining system, Energy Consumption, Greenhouse Gas Emission, PTBA

1. INTRODUCTION

Current global economic conditions have made the coal prices become uncertain. PT Bukit Asam (PTBA) has quickly responded to these conditions by improving operational efficiency, cost control, diversifying export marketing including introducing focused mining patterns, while maintaining environmental sustainability.

One of the operational efficiency programs for cost control and corporate development is Electrification Program where previously mining operations were dominated by fuel-based mining systems. Implementation of Mining Systems with electric-based mining equipment is also designed through stages to adjust to short-term and long-term corporate targets and adjust to the readiness of equipment.

In the framework of such development, PTBA has invested in electricity-based mining equipment by utilizing its competency capacity in managing continuous mining systems and the potential of existing internal resources (Mouth Mine Power Plant) to reduce dependence on fuel consumption. Electrification program has also proven to contribute to environmental sustainability, namely the reduction of energy consumption and greenhouse gas emissions, in accordance with the vision of PTBA to be a world-class energy company that cares about the Environment.

2. EXPERIMENTAL METHOD

Estimation of electricity consumption can be applied to a wide range of analyses that can be used to [1]:

1. Perform or review prefeasibility level studies by using individual estimates or linking them for estimating requirements for vertical integrated mining operations
2. Estimate the economic effects of changes in power rates and fuel costs on producing or planned mining facilities
3. Estimate a component of greenhouse gas contributions produced by the energy source used to generate electricity consumed by a mining operations

Factor that affecting coal mine energy consumption, can be generated from many aspects such as operator practice, operating conditions and also equipment [2]. On the implementation, energy consumption in mine also varies due to the variation of the mine topography, mine equipment characteristics and operational practices.

The diesel or electricity are used for operating dump trucks,

Received: 27 October 2017

Accepted: 9 February 2018

**Corresponding author email: igusman@bukitasam.co.id*

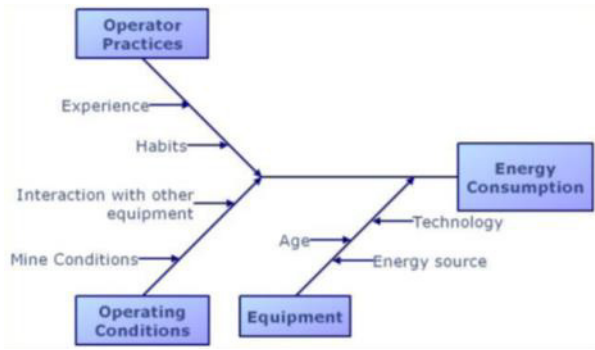

Figure 1. Factors affecting coal mine energy consumption [2]

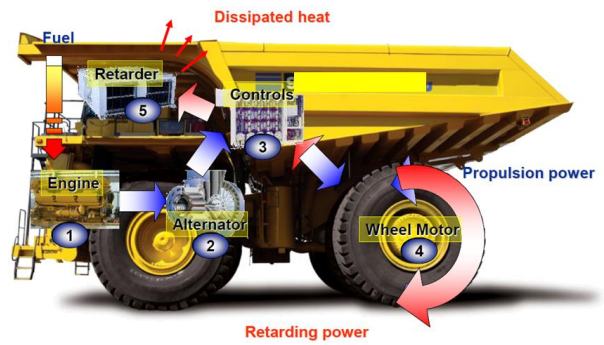

Figure 3. Belaz Truck

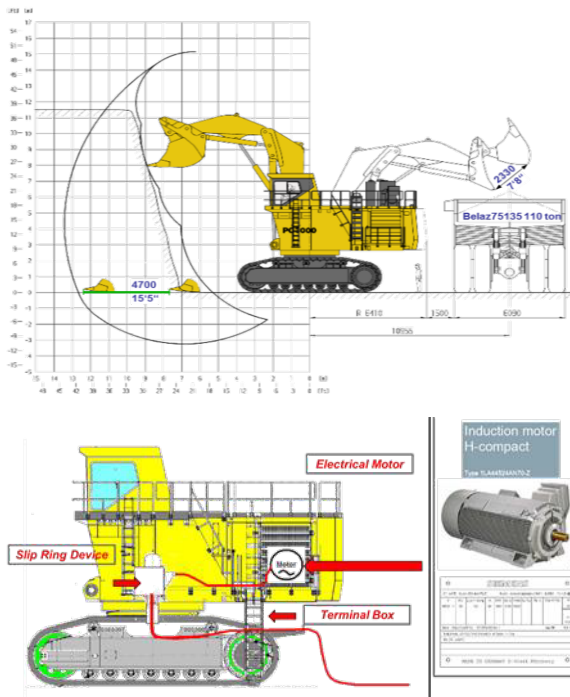

Figure 2. Shovel PC 3000 equipment.

Specification of Electric Shovel PC 3000-6E:

Type	: Hydraulic Shovels
Drive System	: Electric Drive
Output Power	: 900 kW
Bucket Capacity	: 16,0 cum
Crowd Force	: 1100 kN
Break-out Force	: 1000 kN
Boom	: 6,0 m
Stick	: 4,3 m

excavators, shovels, draglines, crushers, conveyors and pumps. Based on benchmarking in Gondegaon opencast mine, input energy profile for conventional opencast coal mine, Electricity has annual energy consumption of 8.203 MU equivalent with 98.760 GJ (36%) meanwhile Diesel has annual energy consumption of 5.019 MU equivalent with 179.195 GJ (64%) [3].

Electrical equipment (electrification) program in PT. Bukit Asam is a new mining method which previously dominated by fuel-based mining systems. Implementation of this program is done by implementing the main equipment of the electric digging tool (shovel) and combined with fuel-based truck.

Specification of Dumptruck BELAZ-75135:

Nominal Payload Capacity	: 110 metric ton : 120 Short ton
Engine	: Cummins K1500E
Transmission	: Electrical Transmission
Ratio	: Electric Speed Ratio up to 4726 Torque Nm
Control System	: Automatic Control System
Top Speed (km/h)	: 48
Front Brakes	: Disk Brake
Rear Brakes	: Disk Brake, Resistor Brake
Gross Vehicle (operating Weight)	: 230.100 kg
Fuel Refill, ltr	: 1900
Tires	: 33.00 – 51

Electrification is environmentally friendly program because it is proven to decrease energy consumption and decrease greenhouse gas emission. The calculation of this decrease is done by using comparison data of electrical-based mining equipment with fuel-based mining equipment.

• **Electric Digging tool (Shovel)**

Equipment used in conducting excavation activities using Electric Shovel PC 3000-6E

• **Transportation (Truck)**

The equipment used in carrying the hauling activity is Dumptruck BELAZ-75135.

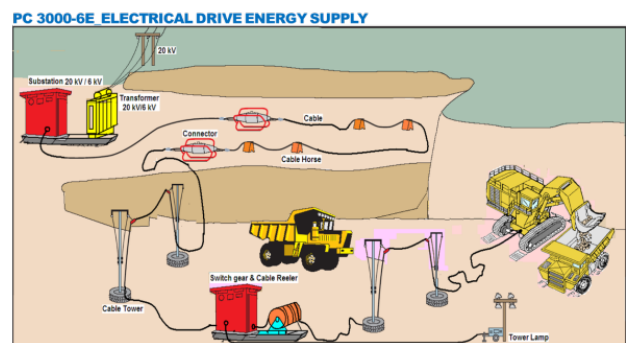

Figure 4. Electrification Mining Process

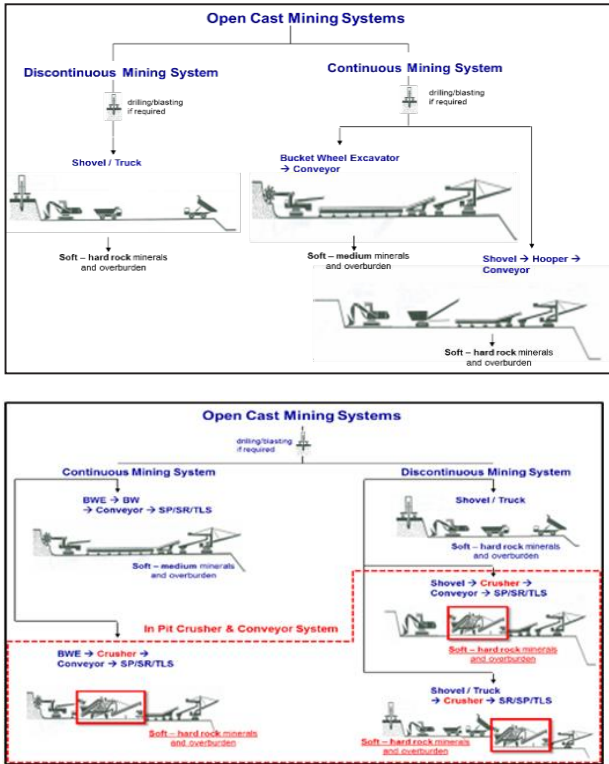

Figure 5. Mining System changes from the old mining system in Pit Crusher & Conveyor (IPCC) system with Electric Equipment

• Electrification Mining Process

Electrification Mining Process is done by implementing the main equipment of the electric digging tool (shovel) and combined with fuel-based truck.

RESULTS AND DISCUSSION

Electrical equipment (Electrification) conducted by PTBA as an effort to maximize electrical energy from Mine mouth steam power plant in Tanjung Enim Mining Unit. Electrification is done by changing conventional mining method based on fuel into base-

Table 1. IPCC system advantages and disadvantages analysis

IPCC System (Shovel à Crusher à Conveyor àSP/SR/TLs)	
Advantages	Disadvantages
1. Electricity cost (Rp./kWh) 40% less cheaper than fuel (Rp ./liter).	1. Limitations of flexibility by using conveyor crusher.
2. Reduce pollution of heavy equipment carbon emissions.	2. Investment cost is higher than shovel & truck.
3. Labor cost, maintenance cost and operating cost are relatively low and less than shovel & truck.	3. For the fully mobile type is resistant to weather, meanwhile semi mobile is vulnerable to weather changes.
4. Can cover the mining distance is relatively fluid and flexible.	
5. Suitable for Soft-hard rock and oversize type of material.	

PC 3000-6E OVERVIEW

PC3000-Electric (Aktual) kWh/h	Electric (Rp/KWh)	Cost Electric Rp/h	PC3000-Diesel Lt/H	Fuel (Rp/Lt)	Cost Fuel Rp/Lt	%	Cost Saving Rp/h
436	1240	540,743	184	8584	1,579,456	192%	1,038,713

PC 3000-6E OVERVIEW

	Total Capacities Per Excavator					Total Consumption Per Excavator (including oil change volume)				
	Engine ltr (US Gal)	PTO ltr (US Gal)	Hydraulic Reservoir ltr (US Gal)	Slew gears ltr (US Gal)	Travel gears ltr (US Gal)	Engine Oil ltr/h (US Gal/h)	Hydraulic Oil ltr/h (US Gal/h)**	Gear Oil ltr/h (US Gal/h)**	Central Lubrication kg/h (lb/h)	Slew ring gear Lubrication kg/h (lb/h)
PC3000 SSA12V159	190 (50.2)	90 (23.8)	2900 (766)	83 (21.9)	135 (35.7)	0.8 (0.21)	0.53 (0.14)	0.10 (0.026)	0.14 (0.31)	0.035 (0.08)
PC3000E	—	90 (23.8)	2900 (766)	83 (21.9)	135 (35.7)	—	0.53 (0.14)	0.10 (0.026)	0.14 (0.31)	0.035 (0.08)

BELAZ75135 OVERVIEW

Belaz75135	Fuel (Rp/ltr)	Cost Fuel Rp/Lt	HD785 Lt/H	Fuel (Rp/Lt)	Cost Fuel Rp/Lt	%	Cost Saving Rp/h
58	8584	497,872	75	8584	643,800	29%	145,928

don electric energy.

The mining method with the IPCC system has several advantages and disadvantages, the following explanation as listed in Table 1.

The results show that IPCC mining method with electrification has more advantages. Electrification succeeded in reducing operating costs by 40% caused by the fuel savings due to switching to electricity.

Table 2 there are cost efficiency in PC 3000 Electric of Rp 37,900,162,944 for 7 units Shovel Electric operates and decreasing oil usage as much as 29.187 liters per year equivalent with Rp. 1.208.904.636. Cost efficiency of usage belaz Truck 75135 amount Rp. 30,423,069,440 for 40 units operates and decreasing oil usage as much 70,883 liters per year equivalents with Rp. 3,849,383,059,20. Table 2 show the complete calculation.

Table 2. Calculation of Decreased Energy Consumption and Emission Reduction

Description	Unit	PC electric	PC Diesel	Information
Energy Consumption	Liter / H	-	184.00	1 Liter BBM = 9240 Kkal
	KWH / H	436.00	-	1 KWH = 860.42 Kkal
	Kkal / H	375,143.12	1,700,160.00	1 Kkal = 4186.8 Joule
	Gjoule / H	1.57	7.12	
	Jam Jalan / Th	5,212.00	5,212.00	
Number Of Unit	Unit	7.00		
	Energy saving	Gjoule	202,397.93	
Energy Consumption		DT Electric	DT Diesel	
	Liter / H	58.70	75.00	
	KWH / H	-	-	
	Kkal / H	542,388.00	693,000.00	
	Gjoule / H	2.27	2.90	
	Jam Jalan / Th	5,212.00	5,212.00	
Number Of Unit	Unit	40.00		
	Energy saving	Gjoule	131,463.80	
Total Energy saving	Gjoule / Tahun		333,861.74	

Description	Unit	PC ELECTRIC	PC DIESEL	Information	
Energy Consumption	Liter / H	-	184.00	Emisi CO ₂ (Diesel) = NCV x FE x Vol BBM	
	KWH / H	436.00	-	Emisi CO ₂ (Electric) = FE x kwh	
Number Of Unit	Jam jalan / Th	5212.00	5212.00		
	unit	7	7		
	NCV	-	0.000036	NCV ³ Diesel = 0,000036 Tj/liter	
	Tj/liter	-	74100	Fe ² CO ₂ (Diesel) = 74.100 Kg/Tj	
	Ke/Tj	-	-	Fe ³ CO ₂ (Electric) = 0,749 Kg CO ₂ /kwh	
	kg/Tj	0.749	-		
CO ₂ Emission	Ton CO _{2e} / Th	11,914.36	17,907.75	FE = Emission Factor	
Emission Reductions	Ton CO _{2e} / Th	-	5,993.39	NCV = Heat Values	
Energy Consumption		PC ELECTRIC	PC DIESEL		
	Liter / H	58.70	75.00		
	KWH / H	-	-		
	Jam jalan / Th	5212.00	5212.00		
	Jumlah Unit	unit	40	40	
		NCV	0.000036	0.000036	
	Tj/liter	-	-		
	kg/Tj	74100	74100		
CO ₂ Emission	Ton CO _{2e} / Th	32,645.49	41,710.59		
Emission Reductions	Ton CO _{2e} / Th	-	9,065.10		
Total Emission reductions	Ton CO _{2e} / Th		15,058.49		

Electrification also reduced energy consumption by 333.861,74 Joule/Years. Decline in energy consumption is also followed by a decrease in greenhouse gas emissions of 15.058,49 Ton CO₂/Year. Inefficiencies that affect electricity consumption in site can occur for many reasons. For example technical problems in hauling road design that decreasing total productivity unit.

CONCLUSION

Comparison of operational costs for the use of electric shovel energy (PC3000-6E) with PC3000 diesel is Rp. 37,900,162,944 for 7 units Shovel Electric operates and decreased oil as much as 29.187 liters per year equivalent Rp. 1,208,904,636.80.

Comparison of operational costs for the use of Belaz 75135 fuel (electric drive) with an equivalent dumptruck (HD785) using mechanical drive is Rp. 30,423,069,440 for 40 units of RT Belaz 75135 operates and decreased oil as much as 70,883 liters per year equivalent Rp. 3,849,383,059,20.

Total Energy savings from implementation of Electrification Program of 333.861.74 GJoule per year.

Total Green House Gas emission reductions from implementation of the Electrification Program of 15.058.49 Ton CO₂e per

year.

There are opportunities to increasing efficiency by optimizing site conditions such as haul road design optimization to increase the productivity unit

REFERENCE

- [1] Bleiwas, Estimates of Electricity Requirements for the Recovery of Mineral Commodities, with Examples Applied to Sub-Saharan Africa, U.S. Geological Survey, 2011
- [2] Awuah-Offei, K., Summers D., Hirsch C. J., Reducing Energy Consumption and Carbon Footprint through Improved Production Practices, Final Technical Report, Missouri University of Science and Technology, 2010
- [3] Indonesia Government, National Inventory Guidance Manual Book 1 Volume 1 Use and procurement of energy Table 2.2 (2012)
- [4] Indonesia Government, National Inventory Guidance Manual Book 1 Volume 1 Use and procurement of energy Table 2.3 (2012)
- [5] Letter of Emission Factor (DJ-ESDM), 2012