

## EFFECTS OF SOIL MOISTURE ON THE GERMINATION AND EMERGENCE OF SUGAR BEET (*Beta vulgaris* L.)

Selostus: Maan kosteuden vaikutus sokerijuurikkaan itämiseen  
ja taimistumiseen

ERKKI AURA

Department of Agricultural Chemistry, University of Helsinki

TO BE PRESENTED, WITH THE PERMISSION OF THE  
FACULTY OF AGRICULTURE AND FORESTRY OF THE  
UNIVERSITY OF HELSINKI, FOR PUBLIC CRITICISM  
IN AUDITORIUM XII ON MAY 7, 1975,  
AT 12 O'CLOCK





## Preface

This study was carried out at the Research Centre for Sugar Beet Cultivation in Salo during the years 1970–74. The subject of the study was suggested to me by the director of the Research Centre, Professor VEIKKO BRUMMER. I am grateful to him for his encouragement of my work at the Centre.

I wish to express my thanks to my teachers Professor ARMI KAILA and Dr PAAVO ELONEN. They have both encouraged me in the execution of this study and have provided laboratory research equipment for my use. In addition to Professor KAILA and to Dr ELONEN, Dr HILKKA SUOMELA has checked the work. I thank them for their valuable criticism of my work.

I would like to thank also, technician VILPPU RISSANEN, who has given me valuable help in the construction of a growth room and laboratory equipment. Mr SULO MONONEN translated my manuscript from Finnish into English and Mr PETER JOY checked the translation. I wish to thank them for their work.

To help finance my research work, I received grants from Agronomien Yhdistys and Henry Ford Foundation. Finally, I am grateful to the Scientific Agricultural Society of Finland for including this study in its series.

Helsinki, January 1975

*Erkki Aura*



## CONTENTS

Abstract .....	7
INTRODUCTION .....	7
A. MATERIALS AND METHODS .....	9
B. STRUCTURE AND GERMINATION OF THE SUGAR BEET SEED .....	11
C. EXCESSIVE WETNESS OF THE SOIL OR SEED AS A DETRIMENTAL FACTOR IN GERMINATION AND SEEDLING EMERGENCE .....	13
1. Effects of excessive wetness of the seed .....	14
2. Emergence in wet soil .....	16
a. Arrangement of experiment .....	17
b. Porosity conditions and gas diffusion in different kinds of seed beds .....	20
c. The effects of air space and diffusion coefficient on the seedling emergence .....	24
3. Discussion .....	25
D. EFFECTS OF INADEQUATE WATER CONTENT OF SEED BED ON GERMI- NATION AND SEEDLING EMERGENCE .....	27
1. Development of research methods .....	27
2. Studies without soil .....	29
a. Arrangement of experiment .....	29
b. Effects of water potential on germination .....	30
3. Effect of soil water potential .....	31
a. Arrangement of experiment .....	31
b. Effects of soil water potential on seedling emergence .....	35
4. Theoretical examination of water movement from the soil to the seed .....	39
a. Suction exerted by the seed .....	39
b. Water diffusivity of the seed .....	42
c. Passage of water into the seed when water diffusivity of the seed bed is not a limiting factor for rate of absorption .....	44
d. Passage of water from seed bed into seed when soil and seed offer resistance to its movement .....	44
5. Movement of water from soil into seed .....	46
a. Determination of water diffusivity for experimental soil .....	46
b. Passage of water from soil into seeds .....	51
6. Effects of poor contact between seed and soil on water intake .....	52
a. Theoretical examination .....	52
b. Experimental results .....	55
7. The ability of the sugar beet seedling to overcome mechanical resistance when the soil water potential is low .....	57
8. Discussion .....	59
SUMMARY .....	63
1. The effects of excessive wetness on germination and seedling emergence .....	63
2. The effects of inadequate moisture on germination and seedling emergence .....	63
REFERENCES .....	66
SELOSTUS .....	69



AURA, E. 1975. **Effects of soil moisture on the germination and emergence of sugar beet (*Beta vulgaris L.*)**. J. Scient. Agric. Soc. Finl. 47:1—70.

*Abstract.* By means of theoretical calculations and laboratory experiments, this study attempted to elucidate the effects of excessive and of inadequate soil moisture on the germination and seedling emergence of sugar beet. The results of this study confirmed the opinion that water contained in the sugar beet seed or surrounding the seed as a water film is a barrier to the adequate intake of oxygen by the seed only when the value of the water potential is close to zero. The soil water potential at which the passage of oxygen into the seed is prevented depends largely on the structure of the seed bed.

With a semi-permeable membrane of cellulose acetate and a solution of polyethylene glycol, it was shown that the sugar beet seed will still germinate fairly well at a potential of  $-10$  atm, but at  $-13$  atm germination is slight. The soil water potential appeared to have nearly the same effect on germination as did the water potential of the polyethylene glycol solution. The seedling emergence percentage was, however, smaller than the germination percentage in experiments with the semi-permeable membrane. This was considered to be caused by the slow extension growth of the radicle due to a low water potential, at the stage of seedling emergence. According to studies made, the initial water intake of the sugar beet seed planted in soil is rapid. Poor contact between the seed and the soil slows down water intake and seedling emergence, but does not impair the final seedling emergence.

Removal of the fruit coat was shown to improve germination markedly when the water potential is low. This treatment would have little practical significance, since the growth of the radicle at a low water potential is very slow.

## Introduction

The use of monogerm seeds in sugar beet cultivation has rapidly become prevalent in Finland during the last few years. In 1968 only about 2.5 per cent of sugar beet seed was monogerm, while in 1971, 84 per cent was (BRUMMER 1972). The change from multigerm to monogerm seeds and from close spacing of seeds to a wider spacing has increased the risk that there will not be enough plants emerging in the sugar beet fields in the spring. The plant stand may be full of gaps and the level of yield may decrease.

Because of the change to wider spacing between plants, intensive research was started in different countries during the last decade to investigate the factors affecting seedling emergence of sugar beet. It soon became clear that seedling emergence in the field was much lower than germination under nearly

optimal laboratory conditions. In practice, seedling emergence was seldom over 80 per cent of laboratory germination (NEEB and WINNER 1968). If conditions in the field are poor, the percentage could be below 50 % (NEEB 1969). Many factors, such as germination energy of seeds, appearance of pathogens in the seed bed, mechanical resistance of the soil surrounding the seed, state of soil aeration and moisture content of the soil, all affect seedling emergence.

Since the reserve food supply of the sugar beet seed is small, the seed should be planted no deeper than 2—4 cm. This shallow planting imposes great demands on the quality of the seed bed. The depth of harrowing must be small and the bottom of the harrowed layer level. In order that sufficient moisture is retained in the germination layer, the soil covering the seed must not be too coarse. Thus many of the studies have been concerned with the effects of soil moisture on seedling emergence and the establishment by cultivation of a seed bed, which would retain the optimum amount of moisture for germination (OEHME 1969, FIEDLER 1970, HEYDECKER and GULLIVER 1972, KLOOSTER and MEIJER 1972, MÜLLER 1972). In Finland, where the spring weather is often dry, studies even before the change to more widely spaced planting emphasized the moisture conditions of the germination layer (BRUMMER 1960). When it became apparent that also here monogerm seed would be taken into use, spring cultivation experiments were made at the Research Centre for Sugar Beet Cultivation in Salo. Particular emphasis has been devoted to finding ways of establishing a seed bed of uniform quality and sufficient moisture in clay soil (ALASTALO 1966, 1968).

During the years 1970—73 the author studied the cultivation of sugar beet soil at the Research Centre. Using soil samples, moisture changes in the harrowed layer during seedling emergence was studied. Very little has, however, been explained of how the sugar beet succeeds in germinating and emerging as a seedling in moist or dry soil. Since so little is known about these factors, it is difficult to interpret the results of moisture content determinations made on soil samples from field experiments. It is apparently impossible to explain precisely through field experiments how seedling emergence depends on soil moisture. Along with cultivation experiments made in the field, the author has studied the effects of soil moisture on sugar beet seedling emergence in the laboratory.

The author considers many of the studies on the effect of moisture on sugar beet seedling emergence deficient in that they fail to take advantage of the findings of soil physics. For example, the moisture condition of the soil is often represented only by its water content determination without measuring how tightly the water is bound in the soil (KLOOSTER and MEIJER 1972, LONGDEN 1972). In the present study, the results of which have been obtained solely through laboratory experiments, an attempt has been made to apply soil physics to set up the experiments and to interpret the results.



## A. Materials and methods

Soils used in the experiments were taken from the cultivated layer of sugar beet fields in Southern Finland near the city of Salo. The characteristics determined for the soils are shown in Table 1.

Table 1. Characteristics of experimental soils.

	pH	Org. C % of DM	Conduc- tance mmho/cm	Particle size distribution, %				
				> 200	60-200	20-60	2-20	< 2 $\mu$ m
Fine sand soil	7.1	2.3	0.51	2	31	52	7	8
Clay soil	7.3	2.8	0.40	10	12	11	26	41

The pH of the soils was measured in a 0.01 M CaCl<sub>2</sub> suspension (RYTI 1964). The organic carbon content was estimated by wet combustion (GRAHAM 1948). The soil water electrolyte content was studied by measuring the conductivity of a water suspension of the soil (BOWER and WILCOX 1965). Particle size composition of the experimental soils was determined by the method of ELONEN (1971).

The varieties used in the studies were monogerm Monohill and Monobeta and multigerm Polyhill and AaBeCe. The seeds of all the varieties were treated with disinfectants. Information about the varieties is shown in Table 2.

Table 2. Experimental varieties.

	Germination on filter paper %				Radicles/ 100 cluster	Diameter mm	1973 % of planted area in Finland
	1 radicle	2 rad.	3 rad.	4 rad.			
Monohill .....	81	4	—	—	89	3.5-4.5	88
Pelleted							
Monohill .....	86	1	—	—	88	4.0-5.0	—
Polyhill .....	74	23	—	—	120	5.0-6.0	5
AaBeCe .....	42	34	7	1	135	3.0-7.0	2
Monobeta ...	78	5	—	—	88	3.2-4.2	—

Germination was studied using folded filter paper at 25° C as in the EIFRIG (1960) method. Size of seed was measured using round hole sieves. Less than 10 % by weight of the seeds exceeded the given size limit. Data collected by the Research Centre from sugar factories, shows the contribution of the test varieties to sugar beet production in Finland in 1973.

Germination and seedling emergence experiments as well as measurements of soil physical characteristics were made in a room where the temperature varied between 19–21° C. In the seedling emergence experiments, the depth of planting in seed bed was always 2 cm. The water content of test soils and seeds was determined by drying at 105° C. Drying times were two hours for seeds and eight hours for soil.

Average results obtained in germination and seedling emergence tests by different experimental treatments were compared using the DUNCAN (1955) test. The confidence level was always 95 %.

## B. Structure and germination of the sugar beet seed

The «seed» of multigermsugar beet is a cluster made up of several separate achenes, each containing only one seed. One to four seedlings will grow from an ordinary diploid or polyploid seed. The monogerm fruit developed by plant breeding is one-seeded. In this study both monogerm and multigermsugar fruits are often called seeds.

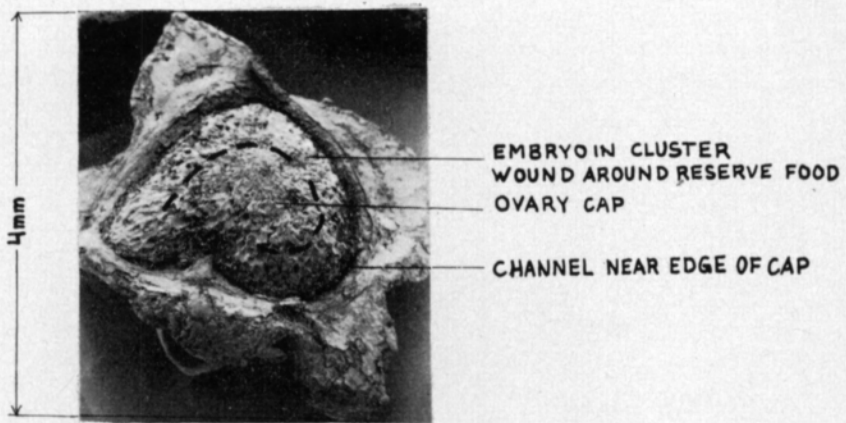

Fig. 1. One-seeded cluster of the genetically monogerm Monohill variety. (Photo M-L. KOSKENPERÄ, Lab. of Electron Microscopy Fac. of Agric. & Forestry Univ. of Helsinki).

A fruit of the genetically one-seeded Monohill variety is shown in Figure 1. The fruit wall is made up of woody cell tissue. The thickness of the wall varies from 0.2 to 1 mm. On the wall is a cap which opens when the seed germinates. The fruit wall is thinnest near the edge of the cap. In Figure 2 the structure of the seed within the fruit is shown. The embryo is curled around the reserve food supply under the seed coat. When the seed has absorbed water from the seed bed, the ovary cap opens under favorable germination conditions within about 1 1/2 days from planting. The embryo is beneath the edge of the cap. Apparently the opening of the cap helps the embryo to obtain water and oxygen during the germination process. Under favorable conditions the radicle pushes out of the fruit within 2 days from planting (Figure 3). This means that the surface area receiving water and oxygen increases in the germinating sugar beet. Upon rising to the surface of the soil, the cotyledons of the sugar

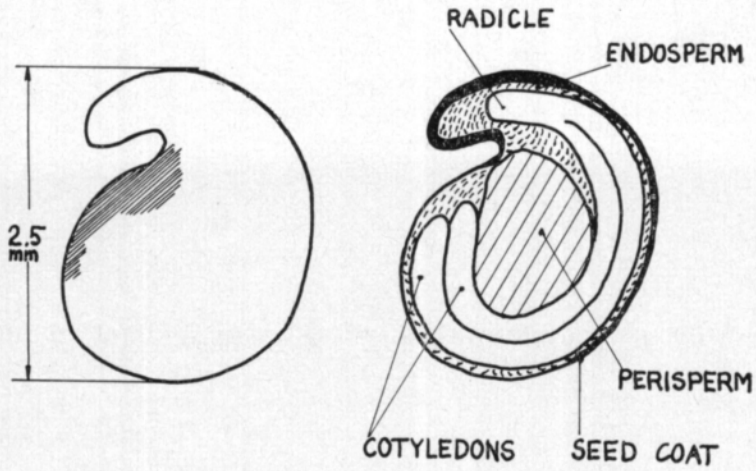

Fig. 2. External view and transection of sugar beet seed (LAKON & BULAT 1958).

beet are near the hypocotyl and bent downward. The »point« of the plant growing upward and penetrating the soil is not sharp, and thus mechanical resistance easily hinders the seedling emergence of the sugar beet.

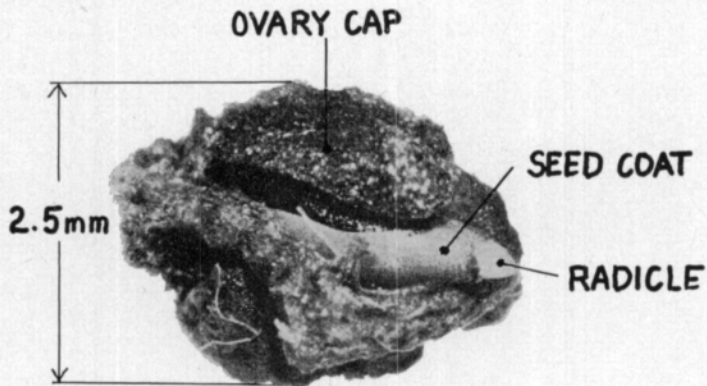

Fig. 3. Opening of the ovary cap and emergence of the radicle. Photo was taken 2 days from planting the seed.

### C. Excessive wetness of the soil or seed as a detrimental factor in germination and seedling emergence

During germination, the seed takes in oxygen and gives off carbon dioxide. The oxygen consumption of the germinating sugar beet seed has so far been only scantily studied. Perhaps the most thorough investigation of this matter has been made by HEYDECKER et al. (1971). However, they measured the consumption of oxygen mainly near moisture saturation. According to their results the consumption of oxygen by a seed during the first 12 hours from planting was about  $0.5 \times 10^{-4}$  cm<sup>3</sup>/h. Later between 25 and 36 hours after germination was started, and the cap on the fruit coat may already be slightly open, the average oxygen consumption was about  $2.5 \times 10^{-4}$  cm<sup>3</sup>/h. In the seed bed the movement of oxygen into the seed and the movement of carbon dioxide outward is based largely on diffusion due to differences in concentrations. Gases diffuse more easily through pores filled with air. The movement of gases through pores filled with water is slow. At a temperature of 20° C the diffusion coefficient of oxygen in air is 0.21 cm<sup>2</sup>/s and in water  $2.33 \times 10^{-5}$  cm<sup>2</sup>/s. Corresponding values for carbon dioxide are 0.16 cm<sup>2</sup>/s and  $1.60 \times 10^{-5}$  cm<sup>2</sup>/s (LAX 1967, WEAST 1969).

The wetter the seed bed and the higher the soil water potential, the greater the number of soil and seed pores which are filled with water and the weaker the exchange of gases. The amount of air space in soil has long been used as a measure of gas exchange taking place in the soil. The amount of air space depends on total pore volume and pore size distribution as well as on soil water potential. If we assume that soil pores are cylindrically shaped tubes, for the largest water filled pores we can calculate the diameter using the formula (e.g. CZERATZKI 1958):

$$d = \frac{0.3}{h} \quad (1)$$

where d = pore diameter in cm

h = absolute value of capillary potential of soil water  
expressed as height of water column in cm

Since the shape of the pores can differ greatly from a cylindrical shape, equation (1) will only give an approximate value of the pore diameter. The ease with which gases can diffuse through soil depends not only on the amount of air space in the soil, but also on the shape and continuity of pores (CURRIE 1961, BAKKER and HIDDING 1970).

Although the soil pore is filled with air, its wall is covered with a thin film of moisture. The thickness of the moisture film increases as the soil water potential increases. Apparently the hydrophilic surface of the sugar beet seed in the soil is also covered by a moisture film wherever the seed touches the air filled pore. Since the diffusion of gases in water is very slow, the moisture film may restrict the intake of oxygen by the germinating seed, and the escape of carbon dioxide from it. It is also possible that in wet soil the pores of the sugar beet fruit coat are completely filled with water, thus preventing the exchange of gases.

Germination experiments made on seeds of various species indicate that lack of oxygen is more detrimental to germination than is a high carbon dioxide content in the air space surrounding the seed (DASBERG et al. 1966). Nor does a large carbon dioxide content in the soil air appear to disturb the germination of sugar beet (THIELEBEIN 1960). According to THIELEBEIN's (1960) study, sugar beet suffers more than many other crops from lack of oxygen due to excessive moisture of the seed bed during germination.

## **1. Effects of excessive wetness of the seed**

Even if the structure of the soil is such that diffusion of oxygen in the soil does not restrict the seed's intake of oxygen, the slow diffusion of gases in the wet sugar beet seed or through the moisture film surrounding the seed may prevent the intake of sufficient oxygen. Experiments have shown that the more water a plant cell tissue contains, the slower the diffusion of oxygen into the cell tissues (OHMURA and HOWELL 1960). In an exceedingly wet soil, the pores of the sugar beet fruit coat are filled with water. It is natural to assume that the removal of the fruit coat would then improve the intake of oxygen. This view is supported by studies made by HEYDECKER et al. (1971). These indicate that when excessive wetness hampers germination, peeling of the fruit or removal of the cap from the fruit coat greatly improves germination of the seed and intake of oxygen. Their experiments also indicate that oxygen enters the seed only near the edge of the cap of the fruit coat, at which point the coat is thinnest.

When the seed is forced to germinate under dry conditions the passage of oxygen into the seed may be easier than under wet conditions if water has not completely filled the pores of the fruit coat. On the other hand, under dry conditions the opening of the cap may be slower, and this could prevent the passage of oxygen to the seed.

Excessive wetness can impair germination in other ways than by hindering the diffusion of oxygen into the seed. Under wet conditions, germination inhibiting substances in the fruit coat may enter the seed and lower germination, especially if the seed's oxygen intake is inadequate (CHETRAM and HEYDECKER 1967). Numerous microbes surrounding the fruit compete with the seed for oxygen. At moisture contents near saturation microbial respiration may reduce the seed's oxygen supply and thus impair germination. The use of seed

disinfectants, however, greatly checks microbial activity (HEYDECKER and GULLIVER 1972).

Studies made by HEYDECKER et al. (1971) indicate that the excessive wetness of seeds decreases germination markedly only when the water potential is close to zero. At a potential of  $-2$  cm, germination is practically optimal. To obtain a better understanding of this matter the effects of water potential on the germination of Monohill seeds was studied. Since it is apparent that the substance used to coat pelleted seeds bars the passage of oxygen into the seed under wet conditions, the effects of pelleting on the germination of Monohill seeds were also studied. The thickness of the pellet coating was about  $0.5-0.8$  mm.

A hole 1 cm in diameter was bored into the bottom of a plastic dish 6 cm high and 7 cm in diameter. A piece of plastic foam was pushed into the hole. The dish was then filled with sand which was compacted with an iron cylinder. The sand filled dishes were placed in a plastic basin whose sides were slightly higher than the tops of the dishes. Enough water was poured into the basin to attain the desired height of water level. After 24 hours, 30 seeds were planted in each dish on the surface of the sand. The basin was covered with plastic. The water potential under which the seed germinated was indicated by the perpendicular distance between the sand and water surface. The potentials studied were  $-1$  and  $-5$  cm. At potentials of  $-10$  and  $-30$  cm experiments were made in sintered glass funnels. Seeds were germinated without soil on the surface of the filter plate. The regulation of potential is shown in Figure

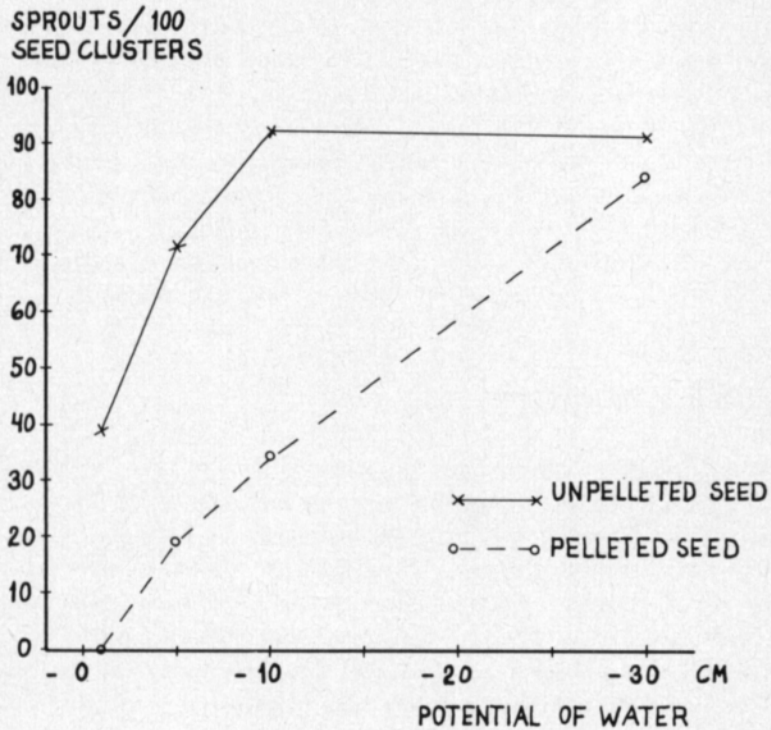

Fig. 4. Effect of the potential of water near saturation on the germination of sugar beet seed.

5, page 17. Germination time in the experiments was 10 days and there were 6 replications.

The germination results obtained (Figure 4) are very similar to those in the studies of HEYDECKER et al. (1971). The germination of unpelleted seed was poor only at a moisture content very near saturation. If the soil surrounding the seed does not hinder the passage of oxygen to the seed, excessive wetness does not, in practice, prevent its germination. Pelletation of the seed greatly impaired germination at moisture contents near saturation. The substance used to coat the seed has hindered the diffusion of oxygen into the seed. Germination has improved as the potential has decreased, and at  $-30$  cm germination is only slightly poorer than with unpelleted seed. At this potential, the coating substance cracked strongly, apparently furthering the intake of oxygen by the seed.

According to the author's observations, the moisture film surrounding the seed does not become visible until the water potential is about  $-1$  cm. The rapid thickening of the moisture film at moisture contents near saturation may be one reason for the abrupt drop in germination noticed. However, according to HEYDECKER et al. (1971) the layer of mucilage gathering on the surface of the seed under moist conditions would be a hindrance to the adequate diffusion of oxygen into the seed.

Since the slow diffusion of oxygen through the moisture film surrounding the seed can be a hindrance to germination only at moisture contents very near saturation, the use of a platinum electrode to measure the availability of oxygen during germination does not appear to be a suitable method. The amount of oxygen diffusing into the electrode depends largely on the thickness of the moisture film on the surface of the electrode, but also on the rapidity of diffusion in the soil surrounding the electrode (LETEY and STOLZY 1964). ERICKSON and VANDOREN (1960) have indeed shown that the larger the oxygen diffusion rate obtained with electrodes immersed in the soil, the better the emergence of sugar beet seedlings in the soil. Studies made with plants other than sugar beet indicate, however, that seedling emergence is more dependent on the oxygen concentration of air in the soil than on the values measured with platinum electrodes (WENGEL 1966, KAACK and KRISTENSEN 1967).

## 2. Emergence in wet soil

Very little work has been done on how wetness in seed beds of different structures affects germination and seedling emergence of the sugar beet. According to the results presented above, excessive wetness of the seed or moisture film surrounding the seed impairs germination only at moisture contents near saturation. Further experiments were made to determine, the point at which too high a water content in the soil surrounding the seed becomes a hindrance to the passage of oxygen and interferes with seedling emergence. The passage of oxygen from the air by way of the seed bed into the seed was studied by determining the amount of air space and the diffusion coefficient of oxygen in the test soil.



*a. Arrangement of experiment*

Seedling emergence was studied in clay soil and fine sand soil. For this experiment the air dry clay soil was separated using a sieve into fractions of particle size from 1–4 mm and of < 1 mm diameter. A particle mixture containing 25 % by weight below 1 mm, 50 % by weight 1–4 mm and 25 % by weight 4–9 mm fractions was also included in the experiment. Square hole sieves were used for fractionation. The length of the side of the square denoted the size of the hole. The particle size mixture included in the experiment was roughly equivalent to the particle distribution obtained in a well cultivated clay soil seed bed, a finding based on experience from harrowing experiments at the Research Centre for Sugar Beet Cultivation.

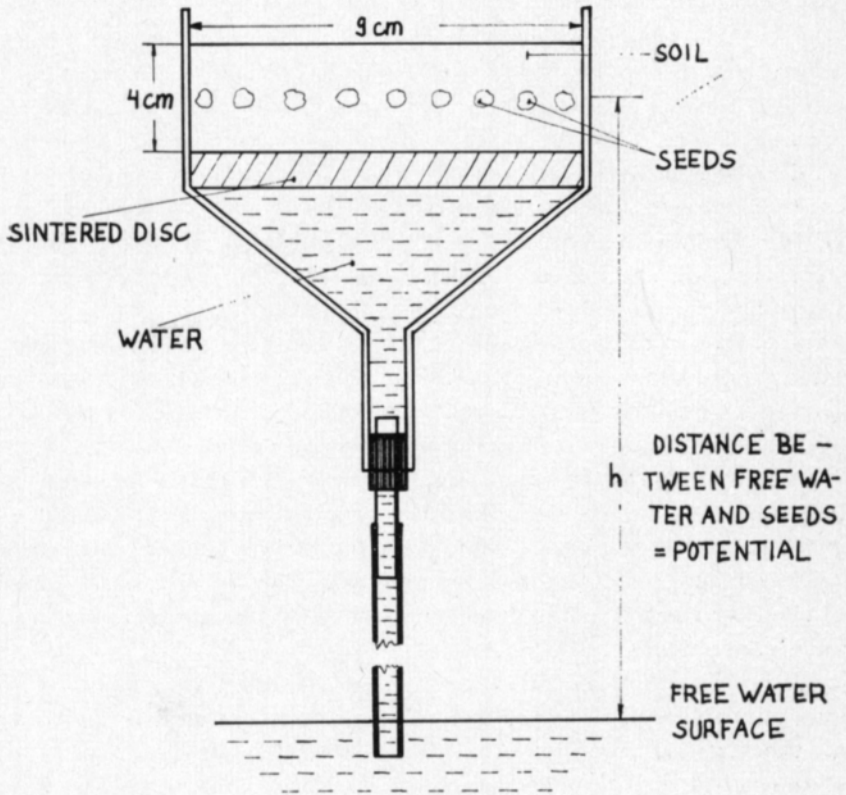

Fig. 5. Schematic diagram of the equipment using sintered glass funnel for germination experiments in moist soil.

Seedling emergence experiments were made in sintered glass funnels as shown in Figure 5. The pore size of the filter was 0.005–0.015 mm. A 2 cm layer of air dry soil was placed into the funnel. The soil was then compacted with a metal cylinder whose weight was such that a pressure of 0.2 kp/cm<sup>2</sup> was exerted on the surface of the soil. Then 30 seeds of Monohill were planted in the sintered glass funnel. After the seeds had been covered with soil, the surface

was compacted again with a pressure of 0.2 kp/cm<sup>2</sup>. After compaction, the planting depth was 2 cm. The soil was kept at saturation wetness for 10 minutes so that the free water surface reached the level of the seeds. Then the free water surface was adjusted to the desired height. Water potentials used were -10, -50 and -100 cm. The water potential of the soil in the sintered glass funnels reached the desired level quickly. After the soil was saturated with water, the lower end of a plastic tube attached to the crucible was set at the height corresponding to the potential being studied. The rate of equilibration could be determined from the dripping of water from the plastic tube. In less than 24 hours the dripping of water stopped completely. This was probably due to the good contact between the sintered glass funnel and the soil and also apparently to the good water permeability of the sintered plate.

Seedlings were counted nearly every day during the period of emergence. When no new seedlings appeared after several countings, the experiment was stopped. At this time the height of the soil in the crucible was measured. The experiment generally lasted 10-15 days. When the equipment was disassembled, the soil was transferred from the crucible into a covered plastic container. The weight of the moist soil and of oven-dry soil were recorded. The soil density was determined for the test soil using the pycnometer method (BLAKE 1965). Since the volume of soil in the crucible was known, it was possible to calculate the proportions of solid substance, water and air space in the test soils using the various measurements taken. There were 6 replications of the experiment.

To determine the diffusion coefficient the soil to be studied was placed into a cylinder with a wire screen bottom. The height of the cylinder was 4.5 cm and the inside diameter was 5.3 cm. The cylinder was approximately half filled with dry soil and then compacted with a metal cylinder of nearly the same diameter. The weight of the metal cylinder was such that a pressure of 0.2 kp/cm<sup>2</sup> was exerted on the soil. Then the cylinder was filled to slightly over the top with soil and again compacted with the metal cylinder. After this the cylinder was placed in a sintered glass funnel. The desired water potential was obtained for the soil in the cylinder in the same manner as in the seedling emergence experiments.

The diffusion coefficient was measured by a method very similar to that used by CURRIE (1960). The principle of the apparatus used for making the determination is shown in Figure 6. Instead of using hydrogen as in CURRIE's method, the gas diffused through the soil into the air was nitrogen. The diffusion of gas in soil is defined by the following equation:

$$\frac{\partial C}{\partial t} = \frac{D}{\epsilon} \frac{\partial^2 C}{\partial x^2} \quad (2)$$

where C = concentration of gas in soil air

t = time

D = diffusion coefficient of gas in soil

$\epsilon$  = portion of soil's total space filled by gas

x = distance in direction of oxygen diffusion from top surface of soil sample

The chamber of the apparatus shown in Figure 6 was filled with nitrogen gas. Then the sample cylinder was attached to the apparatus and the upper plate was rotated until the soil was above the chamber as in Figure 6. The oxygen content ( $C_{O_2}$ ) of the chamber was measured after 900 and 1800 seconds (Beckman Fieldlab Oxygen Analyzer Model 1008). The nitrogen content of the chamber ( $\text{cm}^3/\text{cm}^3$ ) can be calculated from the oxygen content ( $\text{cm}^3/\text{cm}^3$ ) in the following manner:  $C_{N_2} = 1 - 1.046 \times C_{O_2}$ . The oxygen content is multiplied by 1.046 since the rare gases of the air must be taken into consideration. In order to allow application of CARSLAW'S and JAEGER'S (1959) differen-

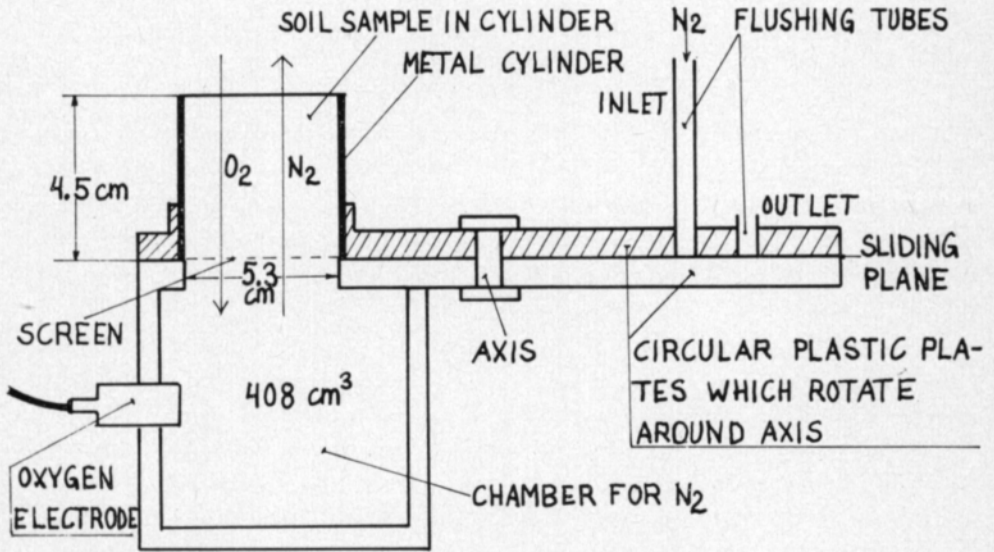

Fig. 6. Diagram of the apparatus used for determining the apparent diffusion coefficient. For filling of chamber with N<sub>2</sub> the upper disc is rotated 180°.

tial equation solution (p. 128, example iv) to equation (2) for calculating the diffusion coefficient, the value of 0 was assigned to the nitrogen content of air. Thus the nitrogen content ( $C_{N_2}$ ) in the chamber is  $C_{N_2} - 0.7808$ . The ratio  $D/\varepsilon$  corresponds to the coefficient of heat diffusivity in CARSLAW'S and JAEGER'S solution. According to Figure 6 boundary conditions are:

$$\begin{array}{ll}
 t = 0 \text{ s} & 0 < x < 4.5 \text{ cm} & C_{N_2} = 0 \text{ cm}^3/\text{cm}^3 \\
 & 4.5 < x < \frac{408 \text{ cm}^3}{3.1416 \cdot \left(\frac{5.3}{2}\right)^2 \text{ cm}^2} & C_{N_2} = 0.2192 \text{ cm}^3/\text{cm}^3 \\
 & & = 18.49 \text{ cm}
 \end{array}$$

$$\begin{array}{ll}
 t > 0 \text{ s} & x = 0 \text{ cm} & C_{N_2} = 0 \\
 & 4.5 < x < 18.49 \text{ cm} & C_{N_2} = \text{same as at surface} \\
 & & \text{of } 4.5 \text{ cm}
 \end{array}$$

When  $x = 4.5$  cm and  $t \gg 0$

$$\frac{C_{N_2}^1}{0.2192} = \frac{2h e^{-D\alpha_1^2 t/\epsilon}}{4.5 (\alpha_1^2 + h^2) + h} \quad (3)$$

where  $h = \epsilon/18.49$

$\alpha_1$  = first positive root of equation:

$$a \tan (4.5 a) = h$$

Since nitrogen contents were measured at times 900 s and 1 800 s, the following expression was obtained for D:

$$D = \frac{\epsilon}{\alpha_1^2 \cdot 900} \ln \left( \frac{C_{N_2}^1 \text{ (at time 900 s)}}{C_{N_2}^1 \text{ (at time 1800 s)}} \right) \quad (4)$$

Using the measured D value we can calculate the relative diffusion coefficient of the gas  $D/D_0$ .  $D_0$  is the diffusion coefficient of nitrogen in air and its value is  $0.21 \text{ cm}^2/\text{s}$  (LAX 1967, GRAY 1972). The value of the relative diffusion coefficient in soil is independent of the gas (PENMAN 1940). Using the ratio  $D/D_0$  we can then calculate the diffusion coefficient of oxygen for the experimental soil.

According to BAKKER and HIDDING (1970), it is not necessary to mix the gases in the chamber during measurement. Oxygen consumption of the soil itself does not cause a significant error in the results. The reading accuracy of the meter used was about 0.1 % by volume. Because the diffusion of nitrogen occurs in oxygen at the same rate as in argon (LAX 1967, GRAY 1972), the rare gases cause only a slight error in the determination of  $N_2$  content. The diffusion coefficient values obtained were corrected to accord with normal air pressure using the following formula (GRAY 1972):

$$D = D_p \frac{P}{760} \quad (5)$$

where D = diffusion coefficient calculated for normal air pressure

$D_p$  = measured diffusion coefficient

P = air pressure in mm Hg during measurement

Water content and bulk density were determined for the soil in the cylinder by drying in an oven. Using the values obtained, proportions of solid matter, water and air space in the soil were calculated. There were 6 replications of the diffusion coefficient determination.

#### *b. Porosity conditions and gas diffusion in different kinds of seed beds*

Porosity conditions of experimental soils in sintered glass funnels are shown in Table 3. In clay soils the smallest air spaces were in  $< 1$  mm fractions.

Table 3. Porosity conditions measured for test soils in seedling emergence experiments using sintered glass funnels.

Potential of soil water cm		Crumb fraction < 1 mm (clay soil)			Crumb fraction 1-4 mm (clay soil)		
		%			%		
		Solid	Water	Air	Solid	Water	Air
- 10 .....	$\bar{x}$	37.4	53.0	9.6	38.5	32.8	28.7
	s	0.8	0.7	1.3	0.0	0.4	0.4
- 50 .....	$\bar{x}$	39.8	44.6	15.6	32.1	26.1	41.8
	s	0.5	0.9	0.9	0.7	0.6	1.3
-100 .....	$\bar{x}$	38.7	34.9	26.4	31.7	24.4	43.9
	s	0.8	0.8	1.6	0.5	0.4	0.8
		Crumb mixture <sup>1)</sup> (clay soil)			Fine sand soil		
		%			%		
		Solid	Water	Air	Solid	Water	Air
- 10 .....	$\bar{x}$	36.2	43.0	20.8	44.6	46.7	8.7
	s	0.7	2.2	2.8	1.4	1.7	2.2
- 50 .....	$\bar{x}$	36.4	34.1	29.5	46.5	44.3	9.2
	s	1.1	1.1	2.2	1.6	1.9	3.2
-100 .....	$\bar{x}$	36.9	31.8	31.3	47.7	32.8	19.5
	s	0.7	0.6	1.6	0.8	2.0	2.8

<sup>1)</sup> Crumbs, <1 mm in diameter, 25 weight- %  
 „ 1-4 „ „ „ 50 „  
 „ 4-9 „ „ „ 25 „

This was to be expected, since in the < 1 mm fractions the intercrumb pores are obviously smaller than in the 1-4 mm fractions or in the particle size mixture. The air space in the < 1 mm fractions has risen sharply when the soil water potential has fallen from -10 cm to -50 cm and from -50 cm to -100 cm. Pore sizes corresponding to these potential ranges are, according to equation (1), 0.3-0.06 and 0.06-0.03 mm. At least in the range from -10 to -50 cm most of the increase in air space seems to result from the emptying of water from intercrumb spaces.

In the 1-4 mm fraction, the air space is already large at a potential of -10 cm. This corresponds to a pore size of 0.3 mm. Evidently most of the intercrumb spaces are larger than this in diameter. The air space has scarcely risen when the potential has decreased from -50 cm to -100 cm. A potential of -50 cm corresponds to a pore size of 0.06 mm according to equation (1). Apparently the intercrumb spaces have almost completely emptied of water

at a potential of  $-50$  cm. The situation is the same in the particle size mixtures, since the air space has scarcely increased when the potential has decreased from  $-50$  to  $-100$  cm.

In the fine sand soil, the air space has scarcely increased when the potential has decreased from  $-10$  cm to  $-50$  cm. This is natural since, according to Table 1, in the fine sand soil most of primary particles are less than  $0.060$  mm in diameter. A pore size of  $0.06$  mm corresponds to a potential of  $-50$  cm, according to equation (1). The air space in fine sand soil has risen sharply when the potential decreased from  $-50$  cm to  $-100$  cm.

Table 4. Relative diffusion coefficients and porosity conditions measured for clay soils in cylinder specimens.

Potential of soil water cm		Solid	% Water	Air	$\frac{D}{D_0}$	$\frac{D}{D_0\epsilon}$
Crumb fraction $< 1$ mm						
$-10$ .....	$\bar{x}$	38.4	52.3	9.3	0.001	0.015
	s	0.7	1.0	0.9	0.001	
$-50$ .....	$\bar{x}$	37.5	46.3	16.2	0.016	0.099
	s	0.5	1.5	1.5	0.008	
$-100$ .....	$\bar{x}$	37.6	35.7	26.7	0.050	0.187
	s	0.5	0.7	1.0	0.009	
Crumb fraction $1-4$ mm						
$-10$ .....	$\bar{x}$	32.8	34.2	33.0	0.102	0.309
	s	1.1	2.2	2.2	0.022	
$-50$ .....	$\bar{x}$	32.6	28.8	38.6	0.164	0.426
	s	1.0	0.2	1.0	0.020	
$-100$ .....	$\bar{x}$	32.7	27.1	40.2	0.173	0.430
	s	0.4	0.8	1.0	0.007	
Crumb mixture:						
$< 1$ mm 25 %, $1-4$ mm 50 %, and $4-9$ mm 50 % by weight						
$-10$ .....	$\bar{x}$	37.6	41.9	20.5	0.042	0.205
	s	0.5	1.9	1.8	0.018	
$-50$ .....	$\bar{x}$	36.6	33.8	29.6	0.100	0.338
	s	0.4	0.9	1.3	0.016	
$-100$ .....	$\bar{x}$	36.7	31.8	31.5	0.117	0.371
	s	0.4	0.6	0.8	0.012	

Tables 4 and 5 show porosity conditions obtained for experimental soils by measurements with cylinders. The values measured for the 1–4 mm fraction of clay soil at a potential of –10 cm clearly differ from the results obtained for soils in sintered glass funnels. The proportion of solid matter in the total volume of soil was markedly greater in sintered glass funnels than in the cylinders. This would seem to result from the visible flattening of 1–4 mm sized crumbs in the sintered glass funnels during the plant growth experiments. The air space in fine sand soil was much greater in the sintered glass funnels at a potential of –100 cm than in the cylinders. This may be due to the cracking of the fine sand soil in the sintered glass funnels at this potential.

Table 5. Relative diffusion coefficients and porosity conditions for fine sand soils in cylinder specimens.

Potential of soil water cm		Solid	% Water	Air	$\frac{D}{D_0}$	$\frac{D}{D_0\epsilon}$
– 10 .....	$\bar{x}$	44.5	47.2	8.3	0.001	0.017
	s	0.8	1.1	1.2	0.001	
– 50 .....	$\bar{x}$	45.4	45.2	9.4	0.026	0.274
	s	0.8	0.9	1.4	0.011	
–100 .....	$\bar{x}$	45.9	38.2	15.9	0.031	0.195
	s	0.8	2.0	2.4	0.005	

The results indicate that the proportion of solid matter in the total volume of fine sand soil increased especially when the potential changed from –10 cm to –50 cm. Soil shrinkage was greater in the sintered glass funnel than in the cylinder.

The relative diffusion coefficients are also shown in Tables 4 and 5. The dependence of the diffusion coefficient on the air space in the soil is shown in Figure 7. The diffusion of gas in soil was almost negligible when the air space was less than 10 per cent. At potentials greater than –10 cm, air spaces appear to have almost no significance in soil aeration in < 1 mm clay soil fraction and in the fine sand soil. The quotient  $D/(D_0\epsilon)$  is used as a measure of pore continuity in Tables 4 and 5. Theoretically continuity has a value of 1 when a gas can diffuse as freely in soil pores as in air. When the air spaces are completely blocked, the value of  $D/(D_0\epsilon)$  is 0. Tables 4 and 5 reveal the tendency of the continuity of air-filled pores to deteriorate with increasing soil water potential and decreasing particle size of the seed bed. In fractions of < 1 mm, continuity is poor at potentials of –50 cm and –100 cm even when the air space is noticeably greater than 10 per cent. This is due apparently to dispersion of the soil during the initial wetting and to the crumbs sticking together.

RELATIVE DIFFUSION  
 $D/D_0$

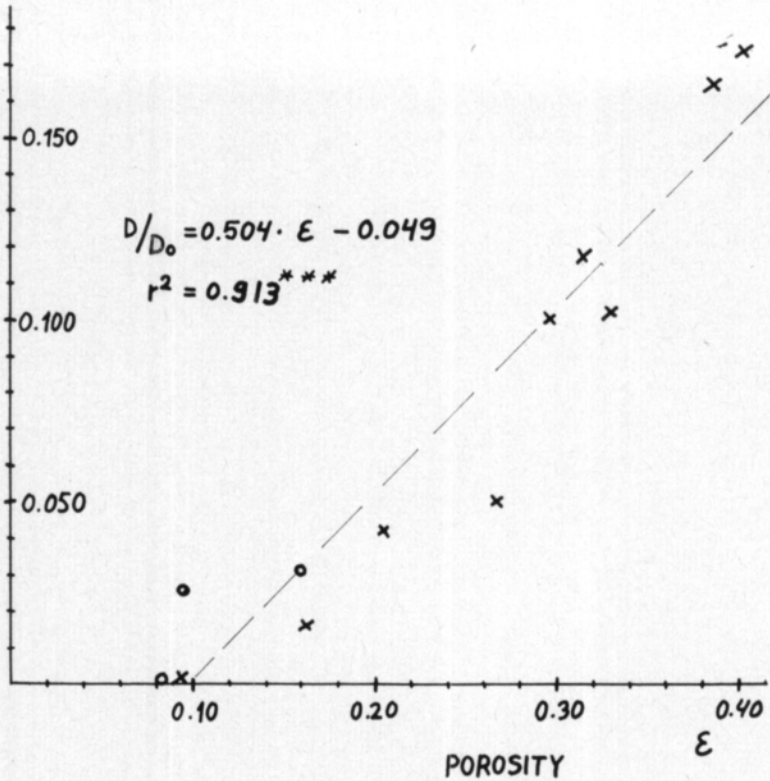

Fig. 7. Relation between the porosity and the relative diffusion coefficient in experimental soils. x = clay soil, o = fine sand soil.

c. *The effects of air space and diffusion coefficient on the seedling emergence*

An attempt was made to clarify the dependence of sugar beet seedling emergence on air space and the relative diffusion coefficient (Table 6). The results show that seedling emergence did not occur at a potential of  $-10$  cm in  $< 1$  mm fractions and in the fine sand soil. The results are obviously due to poor oxygen diffusion in these soils, as shown by measurements. In  $< 1$  mm fractions, seedling emergence was good at a potential of  $-50$  cm, although still significantly poorer than seedling emergence in a particle size mixture at the same potential. The results indicate that excessive wetness will not hinder seedling emergence in clay soil in practice, as long as the soil has not become covered with dispersed soil.

In fine sand soils seedling emergence was surprisingly poor at potentials of  $-50$  and  $-100$  cm. The reason for poor seedling emergence is apparently the substantial soil shrinkage resulting from adjustment of the soil water potential to  $-50$  or  $-100$  cm after the initial wetting. The shrinkage apparently caused the mechanical resistance to become too great for seedling emergence. The



Table 6. Air space, relative diffusion coefficient and seedling emergence in clay soil and fine sand soil.

Potential of soil water cm	Gas filled pores %	$\frac{D}{D_0}$	Seedlings/100 clusters
Crumb fraction < 1 mm			
- 10 .....	9.6	0.001	0.0 <sup>a</sup>
- 50 .....	15.6	0.016	73.9 <sup>bc</sup>
-100 .....	26.4	0.050	85.6 <sup>cd</sup>
Crumb fraction 1-4 mm			
- 10 .....	28.7	0.102	80.0 <sup>bc</sup>
- 50 .....	41.8	0.164	86.7 <sup>cd</sup>
-100 .....	43.9	0.173	83.3 <sup>bcd</sup>
Crumb mixture: < 1 mm 25, 1-4 mm 50 and 4-9 mm 25 weight -%			
- 10 .....	20.8	0.042	71.1 <sup>b</sup>
- 50 .....	29.5	0.100	96.7 <sup>d</sup>
-100 .....	31.3	0.117	82.2 <sup>bc</sup>
Fine sand soil			
- 10 .....	8.7	0.001	0.0 <sup>a</sup>
- 50 .....	9.2	0.026	28.9
-100 .....	19.5	0.031	51.1

Means followed by a common letter do not differ at  $P = 0.05$ .

diffusion coefficients are greater than in < 1 mm fractions at a potential of -50 cm, so seedling emergence would not seem to have been hindered by a shortage of oxygen. Table 6 shows that in 1-4 mm fractions and in the particle size mixture seedling emergence was better at -50 cm than at a potential of -100 cm. The difference is not, however, statistically significant in the 1-4 mm fraction. Even in these soils, the increased mechanical resistance may have decreased seedling emergence as the potential decreased.

### 3. Discussion

The results of this study indicate that water in the sugar beet seed or a water film surrounding the seed can prevent germination by reducing the oxygen supply only at moisture contents near saturation. According to experiments, pelleting of seed increases the detrimental effect of excessive wetness on germination. However, even at a potential of -30 cm the pelleted seed also germinated well. This is evidently due to substantial cracking of the coating

material at this potential. FIEDLER (1970) also has shown that pelleting of seed impairs seedling emergence when the seed bed is very wet. The coating material should be of a kind that will not prevent the passage of oxygen into the seed under moist conditions. At potentials above that of field capacity, the coating material should include plenty of air space, or should crack loose from the seed.

Since the water contained in the unpelleted seed is not a hindrance to germination except under very wet conditions, the seed's supply of oxygen usually depends on the diffusion of oxygen from the soil surrounding the seed. We cannot fully conclude on the basis of the amount of air space in the soil whether or not excessive soil wetness is preventing the seed's getting of oxygen, although this study showed a strong correlation between the diffusion coefficient and air space. The diffusion of oxygen in the soil was negligible when the air space was less than 10 per cent. Naturally, the number of blocked air-filled spaces in the soil, which transfer practically no oxygen, is dependent on the method of moistening the soil.

Germination and seedling emergence of the sugar beet seed was good even when the relative diffusion coefficient was only 0.016 ( $< 1$  mm fraction,  $h = -50$  cm). This is probably because the oxygen consumption calculated per germinating seed is low,  $0.5-2.5 \times 10^{-4}$  cm<sup>3</sup>/h (HEYDECKER et al., 1971). In practice, lack of oxygen will not reduce seedling emergence, provided that the soil is not encrusted. Evidently even in crusted soils, lack of oxygen does not, usually inhibit seedling emergence, but the seedling suffers rather from mechanical resistance which increases because of crusting. Unpublished results of observations made in the field by the Research Centre for Sugar Beet Cultivation indicate that crusting of the soil can depress sugar beet seedling emergence considerably, even when there is plenty of air space ( $\sim 20\%$ ) in the crust layer. In fact, measurements also indicate that when the soil aggregates are very heavily dispersed, there is scarcely any air space even at a potential of  $-300$  cm.

Experimental results indicate that in some cases mechanical resistance may significantly hinder seedling emergence even when the soil water potential is above  $-100$  cm. Thorough studies are needed to determine the significance of mechanical resistance in seedling emergence.

Seedling emergence experiments were carried out on only one variety. Thus it is not clear whether seedling emergence of different varieties would be affected in different ways by lack of oxygen due to excessive wetness of the seed bed. Possible small differences between varieties would probably have very slight practical significance in seedling emergence.

The germination and seedling emergence of the sugar beet seed is apparently seldom inhibited by excessive wetness in the field. In cultivation experiments made by the Research Centre for Sugar Beet Cultivation, moisture determinations indicated that even during an exceptionally rainy spring the germination layer tends to stay in a condition noticeably drier than field capacity. From a practical point of view it is more important to study the effects of excessive dryness than of excessive wetness on the germination and seedling emergence of sugar beet.

## **D. Effects of inadequate water content of seed bed on germination and seedling emergence**

Besides excessive wetness, lack of water in the soil also lowers germination and seedling emergence. As the soil dries, the potential of the water decreases, the hydraulic conductivity of the soil and the seed becomes lower, and the effects of mechanical resistance of the soil on the seed may increase. These factors may together limit the germination of the seed and seedling emergence. In this part of the study an attempt was made to determine what factors decrease germination and seedling emergence in dry soil.

### **1. Development of research methods**

Aqueous solutions of a known osmotic value have often been used to determine the effects of a given water potential on germination. Until recent years, the substances dissolved in water were compounds of low molecular weight such as sodium chloride and various sugars (e.g. WIGGANS and GARDNER 1958). DUBETZ (1958) studied the effects of osmotic potential on sugar beet germination by using ammonium nitrate and mannitol solutions. When the osmotic potential was  $-6$  atm the germination in both ammonium nitrate and mannitol solutions was about 70 %. When the potentials were  $-8$  and  $-10$  atm, the germination percentage in ammonium nitrate solution were 37 % and 2 % and in mannitol solution 46 % and 25 % respectively. Evidently the ammonium nitrate prevented germination by a toxic effect on the seed. It is uncertain whether substances of low molecular weight are at all suitable for the study of the effects of water potential. They may possibly penetrate into the plant and take part in the metabolism. For example, JACKSON (1965) has shown that mannitol in an aqueous solution easily penetrates plant roots and in strong solution hinders plant growth but in a weak solution, promotes it.

HUNTER and ERICKSON (1952) have studied the effects of soil water potential on the germination of sugar beet. Potentials corresponding to the various water contents of experimental soils were based on a moisture characteristic curve obtained by the centrifuge method, which is already out of date. According to their results, sugar beet seed will not germinate if the soil water potential is below  $-3.5$  atm. In the same study, limiting values of  $-6.6$  atm for soya,  $-7.9$  for rice and  $-12.5$  for maize were obtained. Sugar beet, according to

this study, appears to stop germinating at a noticeably higher potential than many other field crops.

The use of large molecule polyethylene glycol (PEG) marked a step forward in the determination of the effects of water potential. In experiments with lettuce and wheat, KAUFMANN and ROSS (1970) obtained similar germination percentages from using filter paper wetted with PEG solution as with soil, provided that the water potential of the PEG solution corresponds to that of the soil. In the same study, the effects of a sucrose solution on germination were entirely different from those of soil water at the same potential.

Recently it has been possible to determine successfully a moisture characteristic curve for soil using polyethylene glycol solution (WILLIAMS and SHAYKEWICH 1969, WALDRON and MANBEIAN 1970). The soil to be studied is placed into a cellulose acetate bag and immersed in the PEG solution of desired osmotic value. The pore diameter of the cellulose acetate membrane is about  $2.4 \times 10^{-8} \mu\text{m}$ . This membrane allows water to pass through, but prevents the passage of PEG. The osmotic method used in the studies mentioned above has produced very nearly the same soil water contents at various potentials as a pressure apparatus. For studying the effects of soil water potential on seedling emergence, the method of KAUFMANN (1969) appears to be very suitable. In his seedling emergence experiments with lettuce, orange and sunflower seeds, he used polyethylene glycol and a semi-permeable membrane to control the soil moisture content. The test soil was placed in a trough made of the membrane.

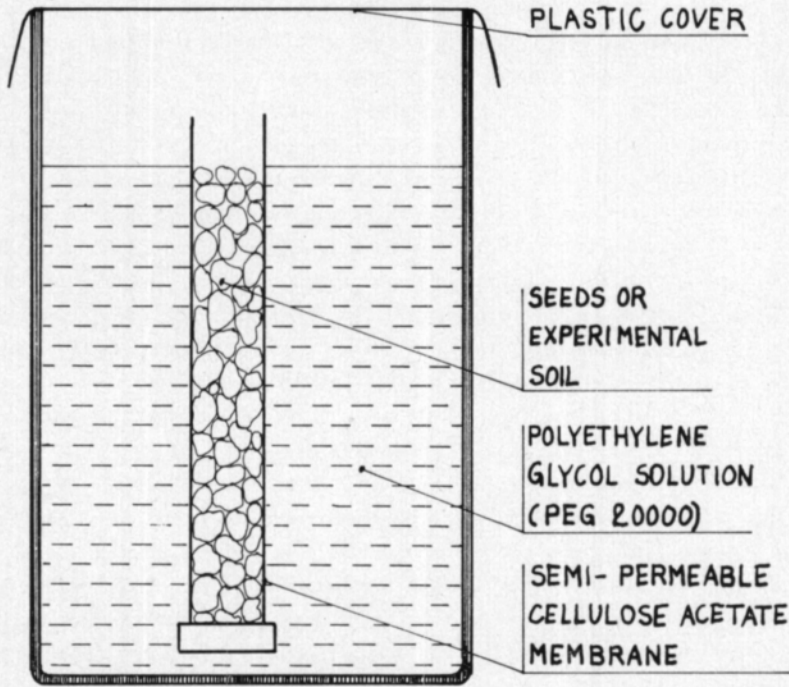

Fig. 8. Cellulose acetate tube and polyethylene glycol solution for the determination of moisture characteristic curve or for germination experiments. Diameter of tube 6.5 mm. The lower end of the tube has been blocked using a bent metal plate.

The trough was immersed in PEG solution, so that the soil water potential was dependent on the osmotic value of the PEG solution. When the moisture content of the soil in the trough reached a state of equilibrium, the seeds of the test plants were planted.

## 2. Studies without soil

### a. Arrangement of experiment

Since experience in the use of PEG solution to control water potential osmotically has been favorable, PEG and a cellulose acetate membrane were used in studies of sugar beet germination. In determining the effects of potential on germination, the seeds were not placed in direct contact with the PEG solution. The seeds were placed in a tube made of semi-permeable membrane, which was immersed in a 500 ml container of PEG solution (Figure 8). The molecular weight of PEG was about 20,000 (manufacturer Fluka). Concentrations corresponding to the desired osmotic values were obtained from the WILLIAMS and SHAYKEWICH (1969) curve based on the determinations of several workers. The concentrations used are shown in Table 7.

Table 7. PEG solutions used in germination and seedling emergence studies.

Potential atm	PEG (20 000) g/ 100 g solution
- 1.0	7.2
- 3.0	14.0
- 5.0	17.4
- 7.0	20.0
-10.0	22.9
-13.0	25.4
-15.0	27.0

To determine how rapidly after placement in the tube the seeds absorb water from the PEG solution and reach a state of equilibrium with respect to water content, a preliminary test with the variety Monohill was made. Solutions of PEG with water potentials of -5, -10 and -15 atm were prepared for the study. Cellulose acetate tubes filled with seeds were immersed in the PEG solution. The rapidity of water absorption was observed through moisture determinations on the seeds. There were 4 replications of the experiment. As Figure 9 shows, equilibrium was reached in about 24 hours. At the lowest potential of -15 atm the seeds did not germinate at all. At -5 atm however, the radicles began to appear 3 days after immersion in PEG solution. As shown in the figure, at potential of -5 atm during germination the seeds have again begun to absorb water rapidly. At -10 atm some of the seeds began to germinate five days after immersion in the PEG solution.

**WATER CONTENT OF SEED  
% OF TOTAL WEIGHT**

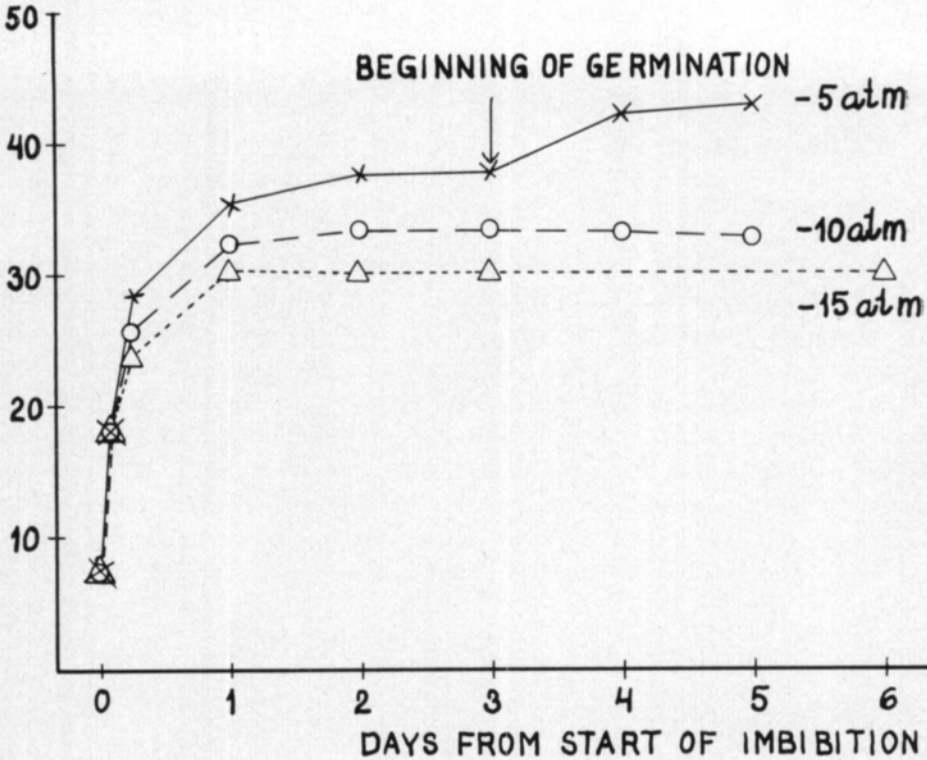

Fig. 9. Absorption of water by sugar beet seed in cellulose acetate tube in PEG solution. Water potentials -5, -10 and -15 atm.

In the actual germination experiment, when seeds were placed as mentioned above in cellulose acetate tubes and the tubes immersed in PEG solution, the germination time was 10 days. It was not possible to use a longer time, since after this, mold began to appear on the surface of the PEG solution. The seed was considered as having germinated if the radicle had come into view through the wall of the cluster. All of the varieties mentioned in Table 2 (except pelleted Monohill) were included in the experiment.

*b. Effects of water potential on germination*

The figures in Table 8 show that germination was good at -7 atm. As the potential decreased from -7 to -10 atm, the germination of multigerm Polyhill and AaBeCe decreased significantly. When the potential fell from -10 to -13 atm, the germination of all varieties was poor. At potentials of -7 and -10 atm the variety AaBeCe which contains the most multigerm seeds produced significantly more sprouts per hundred seeds than the other varieties. At a potential of -13 atm there is no significant difference between

Table 8. Effect of water potential on sugar beet germination. Radicles/100 seeds.

Potential atm	Variety			
	Monohill	Polyhill	AaBeCe	Monobeta
- 7 .....	84.5 <sup>cd</sup>	95.9 <sup>bc</sup>	141.6 <sup>a</sup>	86.1 <sup>cd</sup>
-10 .....	77.4 <sup>d</sup>	78.7 <sup>d</sup>	101.3 <sup>b</sup>	75.5 <sup>d</sup>
-13 .....	11.2 <sup>e</sup>	5.5 <sup>e</sup>	6.8 <sup>e</sup>	9.3 <sup>e</sup>

Means followed by a common letter do not differ at  $P = 0.05$ .

varieties. The results seem to indicate that the germination of the experimental varieties is inhibited in approximately the same degree from low water potential.

In this study, low potential had a less harmful effect on germination than in the experiments of DUBETZ (1958). The reason may be that in his studies the germinating seed was in contact with the aqueous solution, from which the compounds of low molecular weight (ammonium nitrate and mannitol) may possibly have penetrated the seed and taken part in its metabolism.

### 3. Effect of soil water potential

#### a. Arrangement of experiment

Clay soil and fine sand soil were used for studies of the effects of soil water potential. The desired water content for the experimental soils was obtained in the following way: Air dry soil was moistened to a potential of about  $-0.1$  atm and maintained at this water content for about 1 week. Then the soil was spread on a plastic cloth in a layer about 2 cm thick. The soil was allowed to dry. During this time the soil was mixed often. When the desired moisture content was reached, the soil was again carefully mixed and sealed in plastic bags. Then the soil was stored in the bags for at least a week before use, so that any small moisture differences remaining in the soil would be equalized.

Before moistening the aggregate size distribution of the clay soil was determined by sieving as when studying seedling emergence in different fractions of clay soil at high water potential. The distribution was as follows:

Diameter	< 1 mm	37 weight-%
»	1 - 4 mm	50 »
»	4 - 9 mm	13 »

The seedling emergence experiments were made in plastic dishes 5 cm high with a diameter of 14 cm at the top and 8 cm at the bottom. The dishes were filled with test soil to a level of 2 cm from the top. The surface was levelled avoiding compaction. Then 30 seeds were planted in the dish, after which

the dish was filled to the brim with test soil. The soil was not compacted. The dishes were placed in plastic boxes with sides 6.5 cm high. There was 1 cm of water in the bottom of the box. After placing the dishes in the box, a plastic cover was spread over it. The water in the bottom of the box was to prevent the soil moisture content from changing during seedling emergence. If there had been no water in the box, according to measurements made, the soil would have dried during seedling emergence, at a rate of about 0.5 percentage units per week, in spite of the plastic cover.

The seedlings which had emerged were counted every two days. When no new seedlings appeared, the experiment was ended. The length of the experiment varied from 10–30 days.

The moisture characteristic curve, on the basis of which the water potential of the experimental soils was attained, was determined by the osmotic method. The soil was placed in cellulose acetate tubes, like those used to test the effects of water potential on seed germination (Figure 8). To suppress microbial activity, 1 ml of 30 % formalin per 0.5 kg of PEG solution was used. As WALDRON and MANBEIAN (1970) have shown with the osmotic method, a balance between PEG solution and soil is reached quickly. In their studies, an adequate time for ensuring the attainment of equilibrium was 2 days. Also according to the measurements of the author, equilibrium was reached within two days by the osmotic method. For the sake of certainty, however, the tubes filled with soil were kept in PEG solution for 6 days. Test soils were not ground before determination. The initial water content was about two percentage units greater than that obtained osmotically at a potential of  $-1$  atm. The moistening of air dry soil to nearly field capacity and drying again before determination of the retention curve was done in the same manner as when adjusting the soil to the desired moisture content for the seedling emergence experiments. The later procedure was obviously unnecessary, since according to some determinations nearly the same moisture contents at different potentials would have been obtained by filling the tubes with nearly saturated soil.

Moisture content determinations for the experimental soils were also made with a pressure apparatus, using a ceramic plate (potential of  $-1$  atm) and using a membrane (potentials of  $-5$ ,  $-10$ ,  $-15$  atm). The initial potential using the ceramic plate was about  $-10$  cm and using the pressure membrane apparatus about  $-1$  atm.

The water content of soil at  $-15$  atm was also determined by the relative humidity of air. The advantage of this method is that in addition to the so-called matric potential (HILLEL 1971, p. 57) it also takes into account the osmotic potential. The pF value is obtained from the relative humidity by the following equation (HILLEL 1971, p. 73):

$$\text{pF} = 6.5 + \log (2 - \log h) \quad (6)$$

where  $h$  = relative humidity expressed as %.

Using this equation, 99 % relative humidity is equivalent to a pF value of 4.2 or a potential of  $-15$  atm. Slight temperature changes, which change



the relative humidity at the time of determination, greatly disturb the attainment of a true equilibrium within the range of water available to plants. Since the temperature of the room used for making the determinations might vary by as much as 2° C, it was not possible to use a relative humidity greater than 99 %.

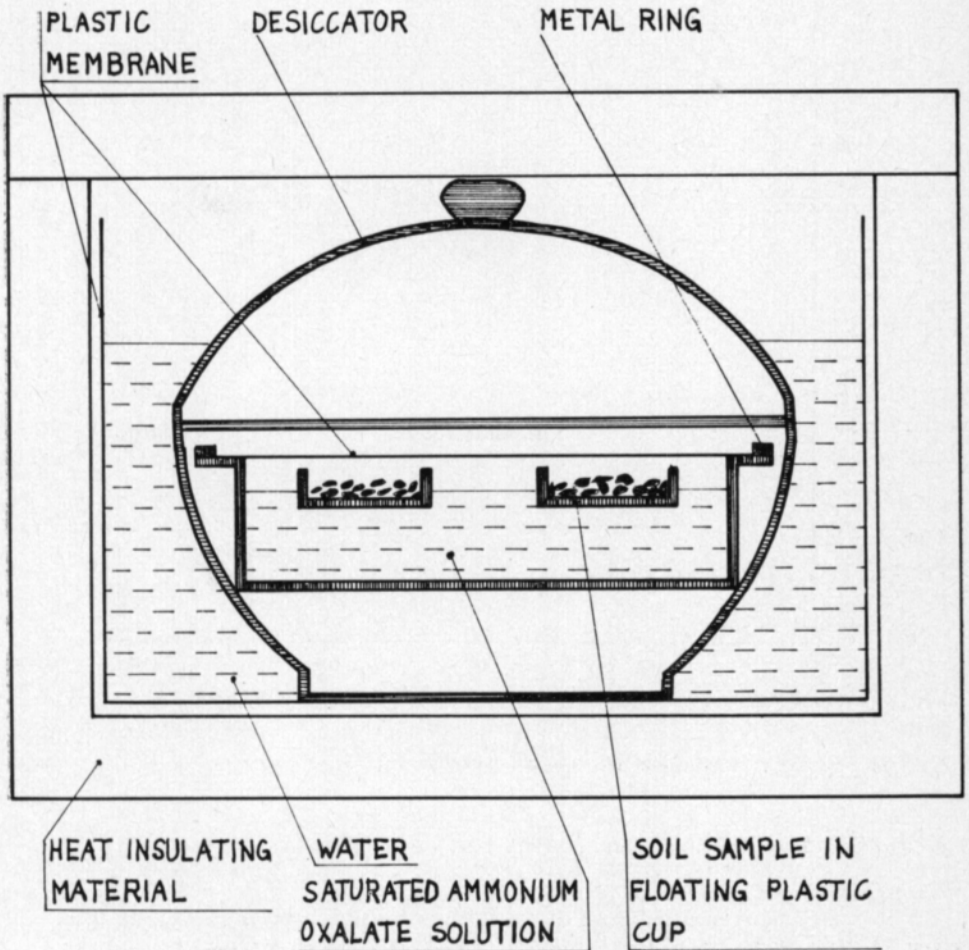

Fig. 10. Determination of soil moisture content corresponding to a potential of -15 atm using the relative humidity method. Relative humidity of 99 % attained using ammonium oxalate solution (The West European Working Group 1967).

Figure 10 shows the experimental arrangement. A plastic desiccator, in which the soil was in equilibrium with the moisture of the air, was immersed in water contained in a heat insulating box. The temperature of water varied by 0.05° C at the most during a 24 hour period. Normal air pressure was used in the desiccator. The initial water content of the soil was about 3 % units greater than the osmotically obtained water content at a potential of -15 atm. Equilibrium was reached within about 2 weeks, according to weighings.

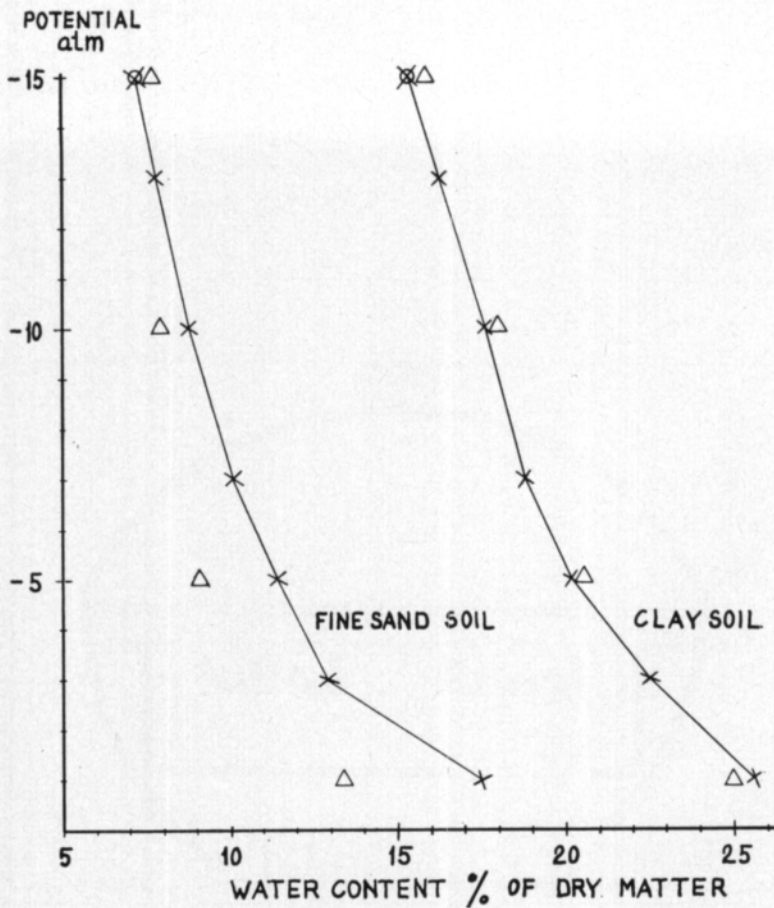

Fig. 11. Water retention curves of experimental soils.

x = osmotic method

Δ = pressure method

o = water content at 99 % relative humidity

The water contents reached at various potentials by the different methods used are shown in Figure 11. Despite the fact that the determination by the relative humidity method could not be done under sufficiently constant temperature conditions, at a potential of  $-15$  atm nearly the same soil water content was obtained by this method as by the osmotic method for both fine sand and clay soils. Using the osmotic method on clay soil, nearly the same water content was obtained at any given potential as was obtained by the pressure apparatus. However, the water contents obtained for fine sand soil at potentials of  $-1$  and  $-5$  atm are clearly lower with the pressure apparatus than with the osmotic method. It was difficult to account for these differing results. Since it could not be proved that the results obtained for fine sand soil by the osmotic method are less reliable than those obtained by the pressure apparatus, the characteristic curve obtained by the osmotic method was used in studies of the effects of soil water potential on seedling emergence.

*b. Effects of soil water potential on seedling emergence*

The results of experiments made to investigate the effect of soil water potential on seedling emergence are shown in Table 9. Seedling emergence in

Table 9. Effect of potential of soil water on seedling emergence. Potential determined osmotically. Seedlings /100 seeds.

Soil water content % of dry matter	Potential atm	Variety				
		Monohill	Polyhill	AaBeCe	Monobeta	
Clay soil						
25.6	- 1.0	84.8 <sup>ef</sup>	101.4 <sup>bcd</sup>	112.8 <sup>ab</sup>	78.6 <sup>ef</sup>	
21.1	- 4.2	89.5 <sup>de</sup>	110.0 <sup>bc</sup>	123.8 <sup>a</sup>	71.9 <sup>f</sup>	
18.9	- 6.8	56.7 <sup>g</sup>	90.5 <sup>de</sup>	77.6 <sup>ef</sup>	37.6 <sup>h</sup>	
16.8	-11.7	5.2 <sup>i</sup>	9.5 <sup>i</sup>	17.6 <sup>i</sup>	7.1 <sup>i</sup>	
Fine sand soil						
15.9	- 1.6	84.3 <sup>o</sup>	109.3 <sup>n</sup>	118.3 <sup>mn</sup>	80.0 <sup>op</sup>	
13.2	- 2.8	73.3 <sup>opq</sup>	107.2 <sup>n</sup>	125.0 <sup>m</sup>	68.9 <sup>pqr</sup>	
10.2	- 6.8	61.6 <sup>qr</sup>	72.2 <sup>opq</sup>	71.1 <sup>opqr</sup>	56.7 <sup>r</sup>	
9.1	- 9.4	25.0 <sup>t</sup>	40.0 <sup>s</sup>	58.3 <sup>qr</sup>	30.5 <sup>st</sup>	
8.0	-12.5	10.0 <sup>u</sup>	7.2 <sup>u</sup>	5.5 <sup>u</sup>	6.7 <sup>u</sup>	

Means for the same soil type followed by a common letter do not differ at P = 0.05.

clay soil did not change significantly in any of the varieties when the potential dropped from -1.0 atm to -4.2 atm. Even in the fine sand soil there is no significant difference between -1.6 and -2.8 atm. As the potential further decreased, seedling emergence abruptly fell off in all the varieties, both in fine sand and clay soils. The table shows that there are no significant differences between the varieties in number of plants at the lowest potentials of -11.7 and -12.5 atm in either soil type. Nor were there any differences in germination between the different varieties at the lowest potential of -13 atm in the experiments with PEG. The results in Table 9 do not indicate that the potential of soil water has a different effect on the seedling emergence of different varieties. The results do show that seedling emergence ceases in all varieties at nearly the same soil water potential. This is supported by an experiment in fine sand soil whose moisture content was 7.6 % of dry matter and its potential -13.8 atm. There was no seedling emergence in any variety at this water content.

By combining figures for all varieties, the mean number of seedlings emerging in both clay and fine sand soil at different potentials was obtained. The figures for germination in PEG were also combined for all the varieties, so that a mean value could be obtained. The results are shown in Figure 12. From

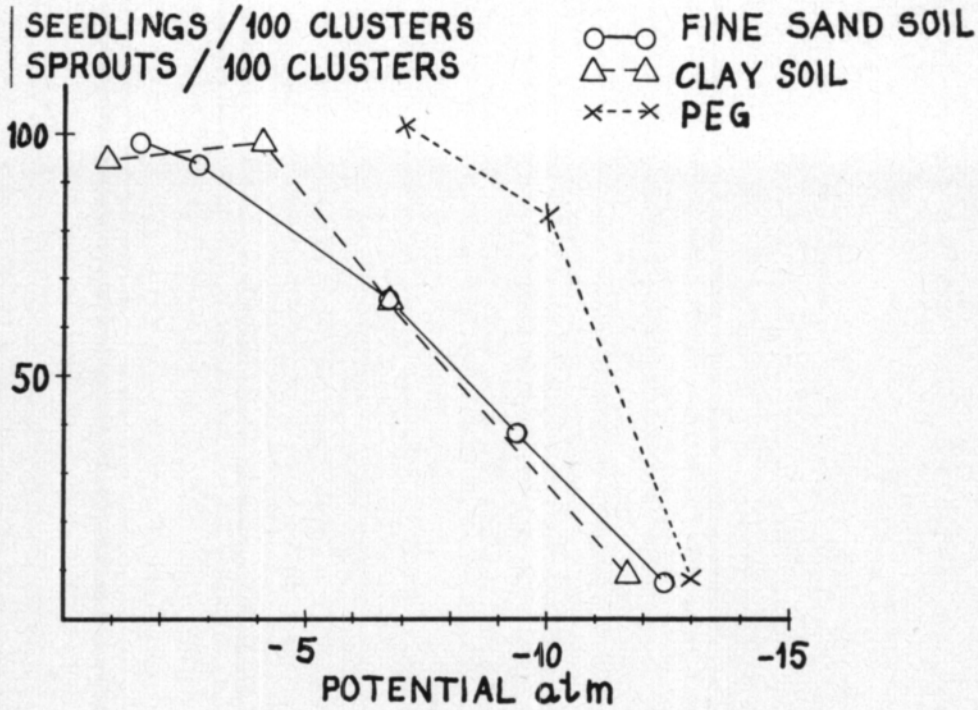

Fig. 12. Average germination of the experimental varieties in cellulose acetate tubes in PEG solution and average emergence in fine sand soil and clay soil.

this we see that on average seedling emergence was nearly the same on both kinds of soil, but varied according to the potential. This result was to be expected, since there is no reason to presume that seedling emergence at a given potential would be different in different soil types. According to conductance measurements, there were slightly more electrolytes in solution in fine sand soil than in clay soil (Table 1 p. 9). However, this small difference is probably not significant from the standpoint of seedling emergence. Germination % in PEG was clearly better than seedling emergence % in soil. This may be due to the following factors:

- The seed actually germinates just as well in soil as in PEG at a given potential, but the elongation of the radicle is so slow that seedling emergence in soil is poorer than germination in PEG.
- Electrolytes dissolved in soil water caused an osmotic potential not accounted for in the method for determining the soil's water retention curve, and impaired seedling emergence.
- The passage of water from the soil into the seed is noticeably slower than the passage from PEG solution through a semi-permeable membrane into the seed. The reason for this may be poor hydraulic conductivity of the soil or poor contact of the seed with the soil.
- Mechanical resistance of the soil hampered germination and seedling emergence.

From the clay soil in which seedling emergence at a potential of  $-11.7$  atm had been studied, the seeds which had failed to sprout and emerge in the three replications were dug up. The results were as follows:

	Monohill	Polyhill	AaBeCe	Monobeta
Percent of planted seeds (including seedlings) found .....	80	92	81	81
Percent of found seeds germinated .....	89	89	86	86

When these results are compared with those from the experiments made with PEG (Table 8), we can conclude that a low potential probably has no more harmful effect on germination in soil than in a cellulose acetate tube in PEG. According to the results there appears to be a contrary tendency, the reason perhaps being that the germination time in PEG was 10 days, while in clay soil at  $-11.7$  atm it was 30 days. Therefore, the slow growth of the sprouts may have been the reason why seedling emergence was poorer than germination in PEG solution. This is supported by the fact that in the experiments made with PEG at  $-13$  atm the sprouts which appeared did not grow any longer than 5 mm within a 10 days period.

The water content determination for experimental soil at a potential of  $-15$  atm with the 99 % relative humidity gave nearly the same result as with the osmotic method (Figure 11). This indicates that the effect of compounds of low molecular weight dissolved in soil water is probably slight. Unfortunately, due to the lack of constant temperature conditions it was not possible to determine the water content of the experimental soil at potentials greater than  $-15$  atm using the relative humidity method. Other possible factors giving rise to the different results obtained with soil and PEG are considered later.

In this study the sugar beet was able to germinate and emerge as seedlings at a lower soil water potential than in the experiments of HUNTER and ERICKSON (1952). According to their experiments, sugar beet would not germinate below a potential of  $-3.5$  atm. A possible reason for the differing results is that HUNTER and ERICKSON used the nowadays obsolete centrifuge method for determining the soil water retention curve. The minimum moisture content at which sugar beet seed would still germinate was, according to HUNTER and ERICKSON, 31 % of the total weight. Figure 9 on page 30 shows that the water content limit for Monohill was almost the same as that obtained by HUNTER and ERICKSON.

To investigate the effects of soil water potential on the rate of germination, the seedlings which had come to the surface were counted every other day. A figure expressing the rate of seedling emergence for the different treatments was obtained by using liner interpolation to determine the number of days after planting when 75 % of the final total of emerged seedlings had appeared. The results are shown in Table 10. The figures indicate a clear tendency. The lower the water potential and the smaller the final number of seedlings, the slower also the emergence. In clay soil at a potential of  $-6.8$  atm AaBeCe emerged significantly more slowly than Monobeta. At a potential of  $-11.7$

Table 10. Effect of soil water potential on rate of seedling emergence. Number of days after which 75 % of final total of seedlings have come to the surface.

Soil water content % of dry matter	Potential atm	Monohill	Polyhill	AaBeCe	Monobeta
Clay soil					
25.6	- 1.0	5.3 <sup>a</sup>	5.9 <sup>ab</sup>	6.6 <sup>ab</sup>	5.5 <sup>a</sup>
21.1	- 4.2	7.2 <sup>abc</sup>	8.3 <sup>abcd</sup>	9.1 <sup>bcde</sup>	7.3 <sup>abc</sup>
18.9	- 6.8	11.3 <sup>def</sup>	11.8 <sup>ef</sup>	14.4 <sup>f</sup>	10.3 <sup>cde</sup>
16.8	-11.7	21.0 <sup>g</sup>	24.5 <sup>h</sup>	22.7 <sup>gh</sup>	20.0 <sup>g</sup>
Fine sand soil					
15.9	- 1.6	6.2 <sup>k</sup>	6.8 <sup>kl</sup>	6.6 <sup>kl</sup>	6.3 <sup>k</sup>
13.2	- 2.8	6.6 <sup>kl</sup>	7.9 <sup>klm</sup>	8.3 <sup>klm</sup>	6.7 <sup>kl</sup>
10.2	- 6.8	9.8 <sup>lmn</sup>	12.5 <sup>nop</sup>	13.3 <sup>opq</sup>	10.6 <sup>mno</sup>
9.1	- 9.4	15.0 <sup>pqr</sup>	17.0 <sup>r</sup>	16.1 <sup>qr</sup>	11.9 <sup>nop</sup>
8.0	-12.5	15.0 <sup>pqr</sup>	17.2 <sup>r</sup>	18.0 <sup>r</sup>	16.0 <sup>qr</sup>

Means for the same soil type followed by a common letter do not differ at P = 0.05.

atm, Polyhill seedlings emerged significantly more slowly than the monogerm varieties Monohill and Monobeta. In fine sand soil at a potential of -6.8 Monohill seedlings emerged significantly more rapidly than AaBeCe, and Monobeta at -9.4 atm significantly more rapidly than Polyhill and AaBeCe.

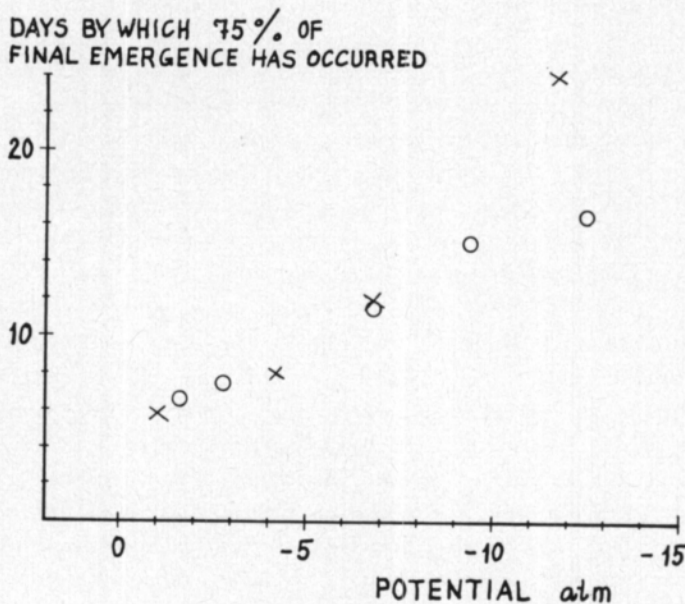

Fig. 13. Effect of water potential on the rate of emergence. x = clay soil. o = fine sand soil. Results are averages of the experimental varieties.

According to the results, seedlings emerge more rapidly from monogerm than from multigerms. The difference seems to be greater at a low soil water potential than at a high one. The effect of potential on the rate of seedling emergence is shown graphically in Figure 13. There does not seem to be any clear difference in rate of seedling emergence between the soil types studied. However, the experiments made on the driest clay and fine sand soils present an exception. Here seedling emergence was much slower in clay than in fine sand soil, even though there was only a slight difference between the values of the potential. Calculation of the rate of seedling emergence in the driest soils gave very questionable results, however, since only a couple of seedlings finally emerged in each of the test containers.

#### 4. Theoretical examination of water movement from the soil to the seed

##### a. Suction exerted by the seed

The difference in water potential between the seed and the soil determines the rate at which the water enters the planted seed. If the seed is stored before planting in a vapor-permeable package, the moisture in the store room air and the water in the seed tend to attain equilibrium. When water neither enters nor leaves the seed, the water has the same potential in the seed and in its surrounding store room air. The pF value of water in the seed is defined by the equation (6) on page 32:

$$pF = 6.5 + \log(2 - \log h)$$

where h = relative humidity of air %

The idea arises of determining the absorptive power of the seed by the relative humidity method. This we clearly can do within that range of potential where the germination process does not yet begin.

In this study the moisture characteristic curve was determined for the variety Monohill. The desired relative humidities were established by using saturated solutions of different compounds. These and their corresponding relative humidities and pF values are shown in Table 11. The experimental setup is the same as in Figure 10 on page 33.

Table 11. Various compounds in saturated solutions and their corresponding relative humidities and pF values. (The West European Working Group 1967, WEAST 1969).

Compound	Relative humidity, %	pF value
K <sub>2</sub> SO <sub>4</sub> .....	97.1	4.6
K <sub>2</sub> CrO <sub>4</sub> .....	88.0	5.2
NaCl .....	75.8	5.6
CaCl <sub>2</sub> · 6 H <sub>2</sub> O .....	32.3	6.2

Air dry seeds were used for determining the water retention curve. For the sake of comparison, clay soil was also used in the determination. The initial water content and particle size distribution were the same as in studying the water content of clay soil by the relative humidity method at a potential of  $-15$  atm (see page 33). The time allowed for attainment of equilibrium was 4 weeks for seeds and soil. Several measurements of water content made earlier indicated that 4 weeks was an adequate time for equilibrium to be reached.

For pF values smaller than in Table 11, we can find the water content of the seed from the curves in Figure 9 on page 30. The figure shows that the seed has already reached a maximum water content at a potential of  $-10$  or  $-15$  atm in 24 hours. Were the seed not to start germinating equilibrium would also clearly be reached in 24 hours at a potential of  $-5$  atm. Therefore water contents of seeds at potentials of  $-5$ ,  $-10$  and  $-15$  atm could be obtained from the curves at the 24 hour point. The water contents of clay soil at various potentials had already been determined osmotically during the seedling emergence experiments.

In order to make comparison easier between water retention curves for seeds and clay soil, water contents were expressed as the amount of water per unit of volume. For this purpose bulk density was determined for clay soil and seed, using for clay soil the same cylinders as in determining the diffusion coefficient for experimental soils. Five cylinders were filled with soil having a moisture content of about 20 per cent of dry matter, in the manner described on page 18. The soil was dried in a drying oven. The bulk density was  $1.07 \text{ g/cm}^3$ .

For seeds, the weight of volume was determined in the following way: A 100 ml graduated glass vessel was filled to about the 75 ml mark with air-dry seeds of known moisture content and weight. A plastic screen was placed over the seeds in such a way that the seeds would not fall out even if the graduated vessel were turned upside down. The vessel was filled to the 100 ml mark with distilled water. The seeds were allowed to remain in the water about 10 minutes. Then the vessel was again filled to the 100 ml mark. The vessel was immediately turned upside down and the water which had surrounded the seeds was collected in a dish. By subtracting the volume of the water and the plastic screen, the bulk density for the seeds was found to be  $0.52 \text{ g/cm}^3$ .

The usefulness of the results is reduced by the fact that both clay soil and seed swell on wetting and shrink on drying, so that the weight of volume depends on the wetness. However, the bulk volume of clay soil as loose particles did not appear, by visual observation, to change in the cylinders during drying in the oven. Using sliding calipers, it was possible to show that the thickness of the seed did not change during soaking, before the beginning of germination. Thus it seemed reasonable to express water content of soil and seeds per unit of volume.

The moisture content of seeds and clay soil at different pF values is shown in Figure 14. Since the moisture of the seed and soil appear, in the range studied, to be linearly related to the pF value, regression equations were computed to show the relation.



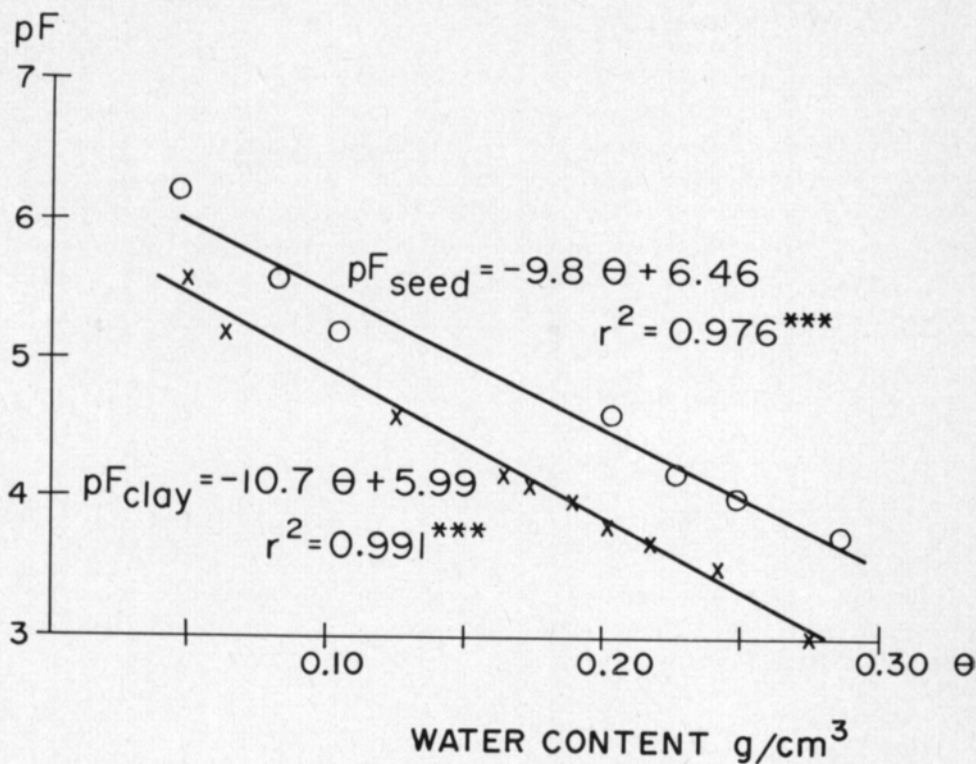

Fig. 14. pF curves of seed and clay soil. pF values above 4.5 obtained by relative humidity method, pF values below 4.5 obtained osmotically.

If the relative humidity of the storage place for the seeds is, for example, 50 %, then according to the equation (6) on page 32 the water potential of the seed is  $-930$  atm. Thus the seed is extremely absorbent when placed in the soil. As the seed becomes moist, however, the absorbency decreases in the manner shown in Figure 14, and at the same time the passage of water from soil to seed becomes slower. The results of this calculation are in agreement with the view expressed in the literature, that the seed is able to absorb water very powerfully (MAYER and POLJAKOFF-MAYBER 1963, p. 38).

If the seed begins to germinate in the soil, forces based on metabolic activity cause water to continue entering the plant after the initial moistening. In studying the effect of potential on the germination of sugar beet seeds, it was found that germination was poor when the water potential was below  $-10$  atm. Below this potential the passage of water into the plant is clearly very slow after the purely physical primary moistening. This is demonstrated in Figure 9 (p. 30) by the change in weight of seed at potentials of  $-10$  and  $-15$  atm. Evidently the absorptive power of the germinating sugar beet seed and seedling after the primary moistening is not much over 10 atm.

*b. Water diffusivity of the seed*

The rate at which water passes from the seed bed into the seed depends also on the seed's water diffusivity. An approximation of the water diffusivity can be obtained by submerging the seed in distilled water and recording the rate of gain in weight of the seed. In computing water diffusivity, the seed is considered to be spherical and homogeneous. This method was used by PHILLIPS (1968) in studying the water diffusivity of soybean, maize and cotton seeds.

In the soil or in a seed (HILLEL 1971, p. 113), we can assume that the movement of water follows the law

$$\frac{\partial \theta}{\partial t} = \nabla \cdot [D(\theta) \nabla \theta] \quad (7)$$

where  $\theta$  = water content of seed (amount of water per unit of volume)  
 $t$  = time  
 $D$  = diffusivity

The effect of gravity has not been taken into consideration in the above equation, on account of its small significance. If the coefficient  $D$  is held constant

$$\frac{\partial \theta}{\partial t} = D \nabla^2 \theta \quad (8)$$

The movement of water into the seed, if the seed is considered spherical, is radial. From this it follows (e.g. CRANK 1970, p. 84) that:

$$\frac{\partial \theta}{\partial t} = D \left( \frac{\partial^2 \theta}{\partial r^2} + \frac{2}{r} \frac{\partial \theta}{\partial r} \right) \quad (9)$$

where  $r$  = distance from center of sphere

Boundary conditions are:

$$\begin{aligned} \theta &= \theta_0 & t &= 0 & 0 < r < 0.15 \text{ cm (radius of sphere)} \\ \theta &= \theta_1 & t &> 0 & r = 0.15 \text{ cm} \end{aligned}$$

where  $\theta_0$  = initial water content of seed  
 $\theta_1$  = water content of seed surface in distilled water

The solution of differential equation (9) by the boundary conditions mentioned has been presented, among others, by CRANK (1970, p. 86). The amount of water  $M_t$  entering the seed in time  $t$  is given by equation:

$$M_t = M_\infty \left( 1 - \frac{6}{\pi^2} \sum_{n=1}^{\infty} \frac{1}{n^2} e^{-Dn^2\pi^2 t/0.15^2} \right) \quad (10)$$

where  $M_\infty$  = water entering the seed over an infinitely long period of time

Note that processes associated with germination reduce the validity of equation (10). The value of  $M_{\infty}$  cannot be determined experimentally, since germination affects the seed's intake of water. The coefficient D is determined from the equation:

$$\frac{M_{t_1}}{M_{t_2}} = \frac{1 - \frac{6}{\pi^2} \sum_{n=1}^{\infty} \frac{1}{n^2} e^{-Dn^2 \pi^2 t_1 / 0.15^2}}{1 - \frac{6}{\pi^2} \sum_{n=1}^{\infty} \frac{1}{n^2} e^{-Dn^2 \pi^2 t_2 / 0.15^2}} \quad (11)$$

Determination of the coefficient D for Monohill variety was done thus: A number of seeds were submerged in distilled water with the aid of a plastic screen. A part of the seeds was transferred after 2, 6 and 24 hours to blotting paper which absorbed the surface water around the seeds. Then a moisture determination was done on the seeds. The initial water content of the seeds was 8.1 percent of dry matter and wetnesses after 2, 6 and 24 hours were 78.8, 97.2 and 114.8 percent of dry matter. The times chosen,  $t_1$  and  $t_2$ , were small, so that the effects of the incipient germination process on the D value to be estimated, would be small. The fact that a smaller D value was obtained when using  $t_1 = 6$  and  $t_2 = 24$  than when using  $t_1 = 2$  and  $t_2 = 6$  (Table 12), may

Table 12. Calculation of water diffusivity for seed. Value of radius 0.15 cm.

Number of hours from immersion of seed into water		Measured $M_{t_1}/M_{t_2}$	Value of D obtained using equation (11)
$t_1$	$t_2$		
2	6	0.792	$1.1 \times 10^{-3}$ cm <sup>2</sup> /h
6	24	0.835	$4.9 \times 10^{-4}$ cm <sup>2</sup> /h

be due to germination already having increased the water intake by the seed. Note that since the value of D varies in different parts of the seed, and the moisture content of the seed affects the value of D, D obtained from equation (11) represents evidently a kind of average diffusivity.

According to the results, the water diffusivity of the sugar beet seed appears to be much smaller than has generally been obtained in measurements on soil. The smallest values of D determined for soil are of the order  $10^{-2}$  cm<sup>2</sup>/h (e.g. DOERING 1965). Results of this study are of the same magnitude as in PHILLIPS (1968) studies. According to his determinations also the D value of a seed is small compared with values obtained for soil. He obtained D values of  $1-3 \times 10^{-3}$  for soybean,  $1-2 \times 10^{-4}$  for cotton and  $8 \times 10^{-4}$  cm<sup>2</sup>/h for maize.

*c. Passage of water into the seed when water diffusivity of the seed bed is not a limiting factor for rate of absorption*

Since experiments described above indicate that the water diffusivity of the seed is considerably smaller than values of  $D$  generally obtained for soil, we can completely ignore the resistance caused by soil in water intake. Thus we can assume that soil has an infinitely large  $D$  value. This assumption makes it possible to calculate, with the aid of equation (10), the rate at which the planted seed approaches equilibrium in water intake. The figures shown in Table 12 can be used as  $D$  values for sugar beet seeds. Boundary conditions are:

$$\begin{array}{ll} \theta = \theta_0 & t = 0 \quad 0 < r < 0.15 \text{ cm} \\ \theta = \theta_1 \text{ (depends on potential} & t > 0 \quad r = 0.15 \text{ cm} \\ \text{of soil water)} & \end{array}$$

Table 13. Attainment of equilibrium in water intake by seed when resistance of soil to water absorption is ignored.

	D value of seed	
	$1.1 \times 10^{-3} \text{ cm}^2/\text{h}$	$4.9 \times 10^{-4} \text{ cm}^2/\text{h}$
$M_2/M_\infty$ .....	0.76	0.58
$M_6/M_\infty$ .....	0.97	0.83
$M_{24}/M_\infty$ .....	1.00	1.00

Results obtained with equation (10) are shown in Table 13. They show that according to the calculations the low water diffusivity of the seed does not retard the passage of water from the soil into the seed to such a degree that germination would be impaired. Equilibrium is nearly reached 24 hours from planting the seed. The seed is not, however, spherical as assumed in the calculation. Because of the wrinkled surface of the seed, with the  $D$  values used, the absorption of water would actually be faster than obtained in theoretical calculations. Because of the wrinkled surface, the  $D$  values obtained by measurements are, however, evidently greater than the true values. For this reason the wrinkled surface may not cause a great error in theoretical calculations of the rate at which water is absorbed from the soil into the seed.

*d. Passage of water from seed bed into seed when soil and seed offer resistance to its movement*

An attempt was also made to determine by theoretical calculations how close an approach to equilibrium can be reached 24 hours after planting, when both seed and soil are resisting the passage of water into the seed. According to Figure 14 (p. 41), pF curves for clay soil and seeds are shown as two almost

parallel straight lines in the range measured. Thus for a given rise in pF value, there is an almost correspondingly large drop in water content in soil and in seed. To simplify the theoretical examination, seed and soil can evidently be considered as a homogeneous material, if it is kept in mind that water contents of the seed are consistently higher than corresponding moisture contents of the soil by about 6 %-units.

CRANK (1970, p. 27) has examined the diffusion of substances in cases where all of the substance diffusing in a homogeneous medium is initially distributed uniformly through a sphere. The concentration  $C$  of the diffusing substance at radius  $r$  from the centre of the sphere and at time  $t$  is:

$$C = \frac{1}{2} C_0 \left\{ \operatorname{erf} \frac{a+r}{2\sqrt{Dt}} + \operatorname{erf} \frac{a-r}{2\sqrt{Dt}} \right\} - \frac{C_0}{r} \sqrt{\frac{Dt}{\pi}} \left\{ -e^{-(a+r)^2/4Dt} + e^{-(a-r)^2/4Dt} \right\} \quad (12)$$

where  $C_0$  = uniform concentration in the sphere initially  
 $a$  = radius of sphere  
 $D$  = diffusion coefficient

This equation was applied to the study of the uptake of water by the seed. The seed's initial water content is represented by  $\theta_0$  and the water content of the surrounding soil by  $\theta_1$ . To the actual moisture content of the soil have been added 6 %-units. The radius of the seed is 0.15 cm. The initial concentration outside the sphere is considered zero and within the sphere, negative or of magnitude  $\theta_0 - \theta_1$ . Substituting into equation (12)  $\theta_0 - \theta_1$  for  $C_0$ , we can calculate the quantity  $\theta(r, t_1)$  in Figure 15. The increase in water content up to time  $t_1$ , at radius  $r$  from the centre of the sphere is  $\theta_1 - \theta_0 + \theta(r, t_1)$ . When  $r = 1/4 \times 0.15$  cm and  $t = 24$  hours:

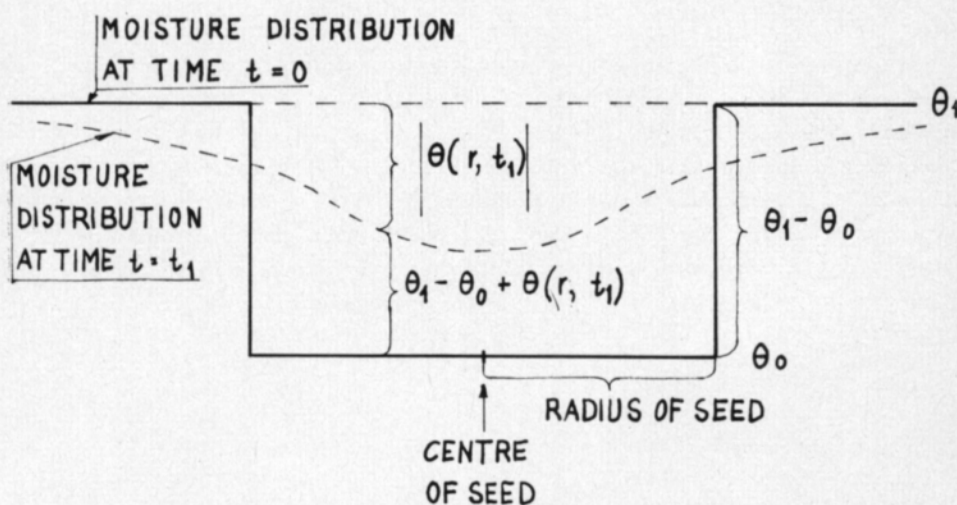

Fig. 15. Application of equation (12) to study intake of water by seed.

$$\begin{aligned}
 &\text{Increase} \\
 &\text{in amount} \\
 &\text{of water} = (\theta_1 - \theta_0) \left\{ 1 - \left[ \frac{1}{2} \left( \operatorname{erf} \frac{0.01914}{\sqrt{D}} + \operatorname{erf} \frac{0.01148}{\sqrt{D}} \right) \right. \right. \\
 &\quad \left. \left. - 73.72 \sqrt{D} \left( -e^{-0.0003663/D} + e^{-0.0001318/D} \right) \right] \right\} \quad (13)
 \end{aligned}$$

Table 14. Theoretical calculation of attainment of equilibrium when water is absorbed from soil into seed.

Water diffusivity of seed and soil	Increase of water content at 1/4 radius from center of seed 24 hours after planting
$10^{-2}$ cm <sup>2</sup> /h	$1.00 \times (\theta_1 - \theta_0)$
$10^{-3}$ »	0.93 »
$10^{-4}$ »	0.23 »
$10^{-5}$ »	0.00 »

$\theta_1$  = water content of seed after attainment of equilibrium

$\theta_0$  = initial water content of seed

The size of the expression in parentheses for different values of D is shown in Table 14. From the results of the calculation, it is evident that absorption of water from the soil by the seed has nearly reached equilibrium in 24 hours if the D value of soil and seed is  $10^{-3}$  cm<sup>2</sup>/h. Attainment of equilibrium is greatly slowed down when the D value decreases from  $10^{-3}$  to  $10^{-4}$  cm<sup>2</sup>/h.

## 5. Movement of water from soil into seed

### a. Determination of water diffusivity for experimental soil

Experiments on the movement of water from soil into seeds were done on clay soil, the particle size distribution of which is shown on page 31. Water diffusivity was determined by using the same principles which have been in general use in studying the diffusion of metals or fluids (CRANK 1970, pp. 232–233). The method is shown in Figure 16. First we bring together two soil samples of water content  $\theta_1$  and  $\theta_2$ . Water then passes from moister to dryer soil. The broken line in the figure shows the moisture distribution at the time  $t = t_1$ . The initial conditions of the experiment are:

$$\begin{aligned}
 \theta &= \theta_1 & x < 0 & \quad t = 0 \\
 \theta &= \theta_2 & x > 0 & \quad t = 0
 \end{aligned}$$

In a one-dimensional case equation (7) on page 42 changes to equation

$$\frac{\partial \theta}{\partial t} = \frac{\partial}{\partial x} \left( D(\theta) \frac{\partial \theta}{\partial x} \right) \quad (14)$$

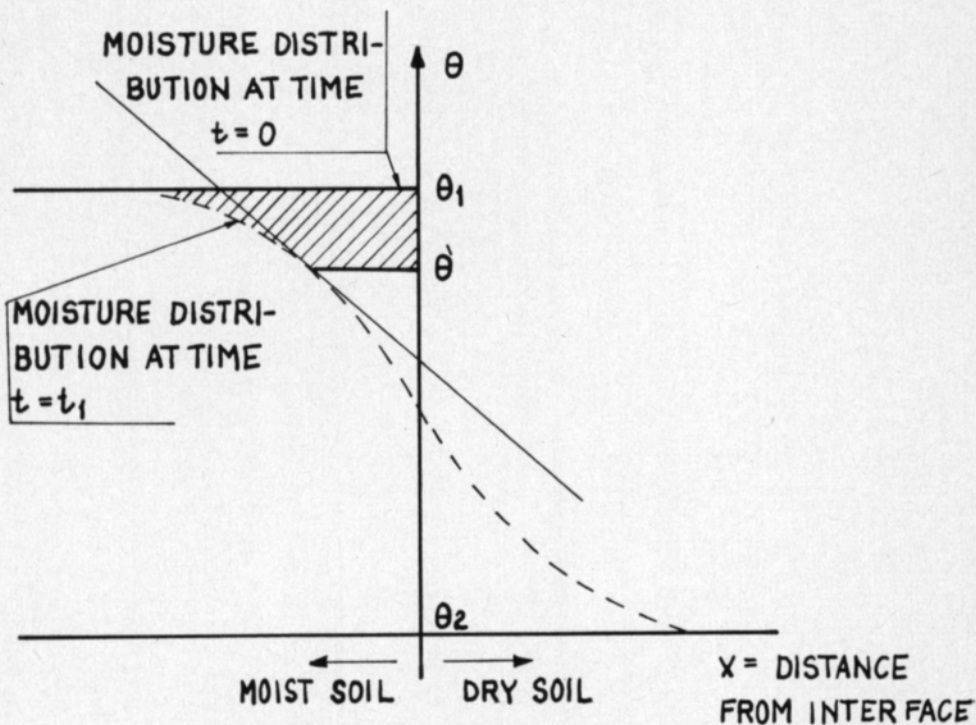

Fig. 16. Evaluation of  $D$  from a moisture distribution curve.

Using the Boltzmann-transformation ( $\eta = x/2\sqrt{t}$ ) we get

$$-2\eta \frac{d\theta}{d\eta} = \frac{d}{d\eta} \left( D(\theta) \frac{d\theta}{d\eta} \right) \quad (15)$$

On integration with respect to  $\eta$

$$-2 \int_{\theta'}^{\theta_1} \eta d\theta = \left[ D(\theta) \frac{d\theta}{d\eta} \right]_{\theta=\theta'}^{\theta=\theta_1} = - \left( D(\theta) \frac{d\theta}{d\eta} \right)_{\theta=\theta'} \quad (16)$$

$$\left( D(\theta) \frac{d\theta}{d\eta} \right)_{\theta=\theta_1 \text{ or } \theta_2} = 0 \quad (17)$$

Introducing  $x$  and  $t$  we have

$$D(\theta') = \frac{1}{2t_1} \frac{dx}{d\theta} \int_{\theta'}^{\theta_1} x d\theta \quad (18)$$

The value of the derivative  $dx/d\theta$  at  $\theta'$  and the value of the integral

$$\int_{\theta'}^{\theta_1} x d\theta \quad \text{we get graphically.}$$

It follows from equations (16) and (17)

$$\int_{\theta_2}^{\theta_1} x d\theta = \int_{\theta_2}^{\theta_1} \eta d\theta = 0 \quad (19)$$

From this we see that the position of the  $\theta$  axis is at the boundary between the two soil samples brought together.

Soil water diffusivity was determined with the aid of plastic cylinders cut in half longitudinally. The dimensions of this trough are shown in Figure 17. In filling the trough, a 1 mm thick metal plate was used, so that the bound-

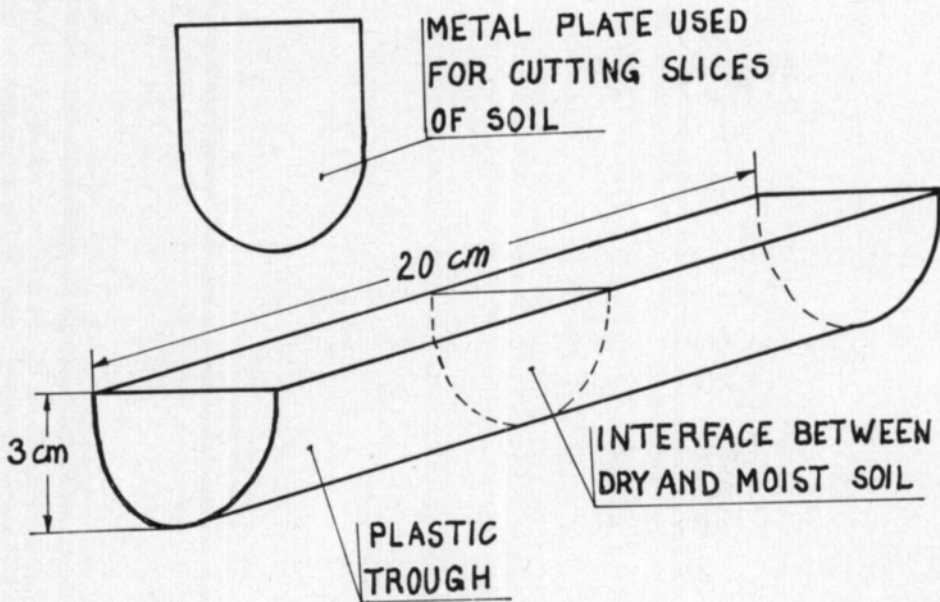

Fig. 17. Determination of soil water diffusivity using plastic trough.

ary surface between the samples could be made vertical in relation to the top surface of the soil in the trough. This plate, which had a sharpened edge, was also used at time  $t_1$  to cut vertical slices at distances of 0.5 cm apart, which were then used to make moisture determinations. After filling, the soil



in the trough was compacted with a pressure of 0.2 kp/cm<sup>2</sup>. A metal plate was placed on the soil-filled trough and weighted down to produce the desired pressure on the soil surface. Then the trough was covered with a plastic membrane using tape to make it airtight.

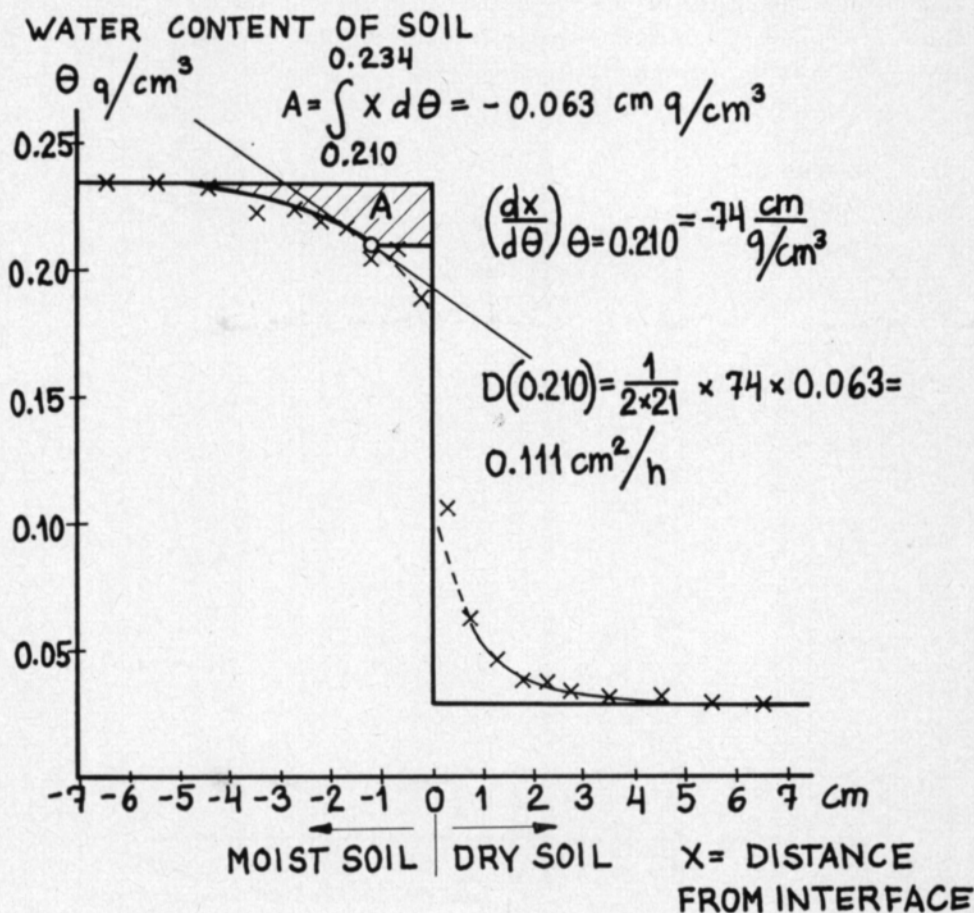

Fig. 18. Calculation of soil water diffusivity from a moisture distribution determined 21 hours after connection of dry and moist soil.

In Figure 18 can be seen an example of the results of a moisture determination made when  $t = 21$  hours and the calculation of diffusivity for  $\theta = 0.21 \text{ g/cm}^3$ . The curve depicting moisture distribution was drawn with the aid of mathematical levelling of points (LINDELÖF 1932, p. 111). As can be seen from the figure, due to hysteresis the water content of the drying soil at the boundary between soils in the trough is greater than that of the soil increasing in moisture. The discontinuity of the moisture distribution curve at the boundary surface could evidently be eliminated by raising the moisture content of the soil to which moisture is being transferred, by the amount of the hysteresis effect.

The results obtained from the various determinations are summarized in Figure 19. There appears to be a minimum diffusivity which is typical for soil (HILLEL 1971, p. 113). On the basis of Figure 19, we can conclude that for a given value of the diffusivity, a soil which is increasing in moisture always has a lower water content than drying soil. At a given potential, the excess amount of water in the drying soil over that in the soil which is increasing in moisture content is evidently situated in pores so blocked that they have no great significance for water diffusivity.

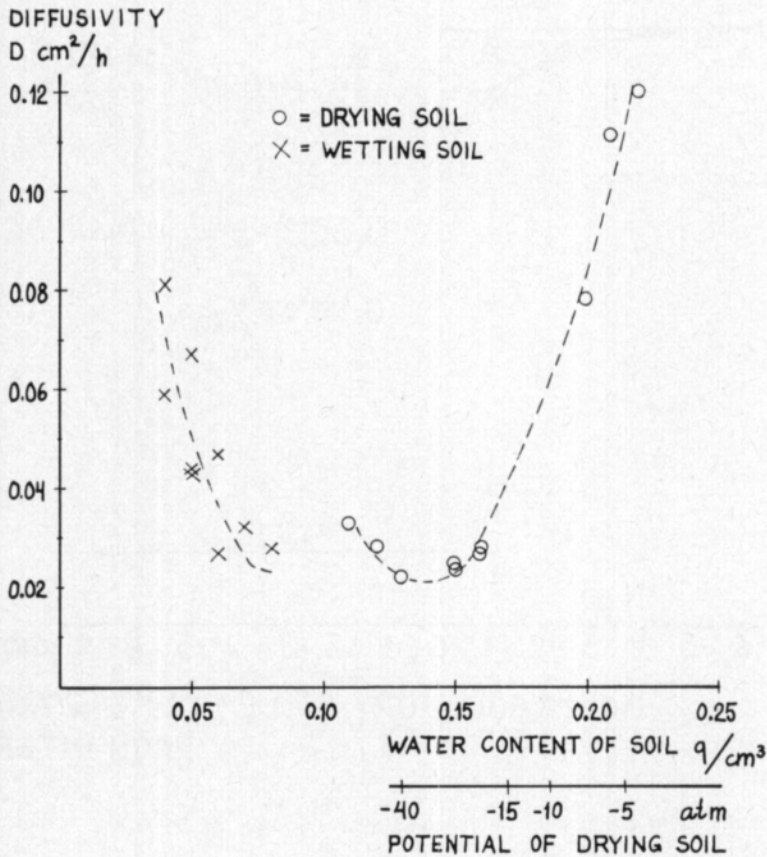

Fig. 19. Soil water diffusivity of clay soil. Broken line drawn freehand.

The lowest water diffusivity value obtained for clay soil is much larger than the diffusivity values obtained for seeds. Thus the passage of water from soil to seed would seem to follow the model set forth in chapter 4 c (p. 44) or an intermediate form of the models in chapter 4 c and 4 d (p. 44).

This method of measuring the water diffusivity of soil, which has perhaps never before been used in soil physics, is very useful if the soil is in small crumbs or primary particles. The equipment required is very simple and it is possible to determine the water diffusivity of very dry soil with this method.

b. Passage of water from soil into seeds

The movement of water from soil into the seed was studied in the following way: Clay soil and about 50 seeds of the variety Monohill were mixed into plastic dishes 6 cm high and 7 cm in diameter. Then the soil was compacted with a metal cylinder which just fitted and could be sunk into the dishes, and of a weight such as to exert a pressure of 0.2 kp/cm<sup>2</sup> against the surface of the soil. The particle size distribution of the clay soil was the same as in the study of the effect of soil water potential on seedling emergence (p. 31) and the desired water content of the soil was obtained by the same method as in that study. After a given length of time, the seeds were dug out from the soil and the soil which had stuck to them was rapidly shaken off and a moisture determination of the seed was made. There were at least 4 replications of the experiment. The results of the moisture determinations are shown in Figure 20.

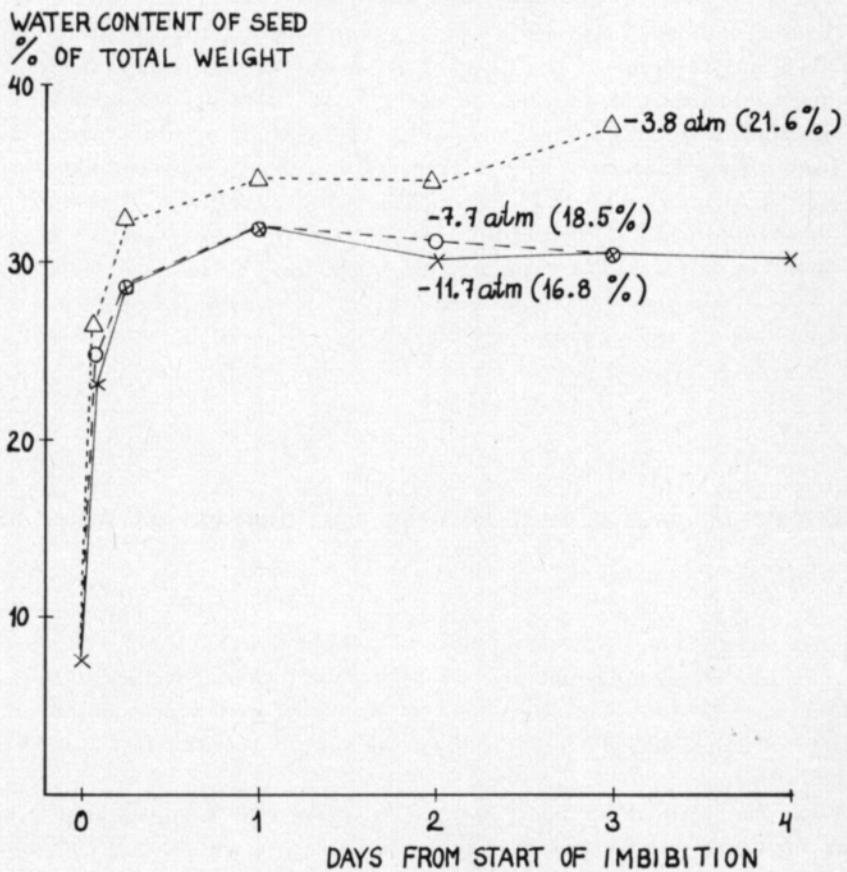

Fig. 20. Absorption of water by seed in clay soil. Potentials of soil water  $-3.8$ ,  $-7.7$  and  $-11.7$  atm.

It was not possible to remove all the soil which had stuck to the seeds before making the moisture determinations. The moister the soil in which the seeds had been mixed and the longer the seed had been in the soil, the more

firmly the soil had stuck to the seeds. For this reason as shown in Figure 20 the water content of the seed appears to have decreased after reaching maximum at potentials of  $-7.7$  and  $-11.7$  atm. After 24 hours at  $-11.7$  atm, very little soil stuck to the seeds. At this potential, the water content of the seed 24 hours after being mixed in the soil was 32.0 percent. In the experiments with PEG the seed reached a water content of 32.3 percent at  $-10$  atm and 30.4 percent at  $-15$  atm after 24 hours. The result obtained with soil was thus almost what one would expect on the basis of the experiments with PEG.

The experimental results obtained for the passage of water from the soil into the seed are in agreement with those obtained theoretically. Initially, the passage of water into the seed is very rapid. Near equilibrium, the rate of absorption slows down very much. The passage of water has nearly attained equilibrium within 24 hours from planting. Since very little soil stuck to the seeds at a potential of  $-11.7$  atm for 24 hours, it is reasonable to compare the results obtained at this potential with those theoretically obtained. The initial water content of the seed was 8.1 % of dry matter and the water contents after 2, 6 and 24 hours in the soil 30.1, 40.0 and 47.1 % of dry matter. If we consider equilibrium in the movement of water from soil to seed as having been reached within 24 hours, and assign the amount of water which entered the seed during that time the value of 1, in 2 hours the seed has absorbed 0.56 and in 6 hours 0.82 of the total amount. Very nearly the same values have been obtained by theoretical means, when the resistance of soil to the movement of water was not taken into consideration, and the D value used for the seed was the measured value  $4.9 \times 10^{-4}$  cm<sup>2</sup>/h. Theoretical results corresponding to the experimental figures above are 0.58, 0.83 and 1.00 for 2, 6 and 24 hours (Table 13, p. 44).

## 6. Effects of poor contact between seed and soil on water intake

### a. Theoretical examination

Observations made in field trials have indicated that too coarse a seed bed may hinder seedling emergence of sugar beet (MÜLLER 1972). It is often thought that the unfavourable effect of a coarse seed bed is based on poor contact with the soil, which slows down the supply of water to the seed (HAMMERTON 1961).

When the seed is in poor contact with the soil, a considerable amount of the surface of the seed is exposed to the air space in the soil. Presumably water also enters the seed in the form of vapor. Liquid water in the soil vaporizes, passes into the seed and condenses again. It is important to know how well moisture passes into the seed by way of the air space.

To answer this question, a calculation was made of the correspondance between soil water diffusivity and the diffusion coefficient of water vapor. The resistance created by the vaporization of soil water and condensation in the seed was not taken into consideration in this study. If there were in the

diffusion path of the water vapor an infinitely short distance of soil through which the passage of water were as rapid as in air, the following equation would hold:

$$q = -Dv \frac{dc}{dx} = -Ds \frac{d\theta}{dx} \quad (20)$$

where  $q$  = flow velocity  $g/cm^2 h$   
 $c$  = concentration of water vapor  $g/cm^3$   
 $\theta$  = water content of soil  $g/cm^3$   
 $Dv$  = diffusion coefficient of water vapor in air  $cm^2/h$   
 $Ds$  = soil water diffusivity  $cm^2/h$

According to the gas laws, the concentration  $c$  of water vapor corresponds to a partial pressure  $p$  thus:

$$P = \frac{1000 c RT}{M} \quad (21)$$

where  $T$  = temperature  $^{\circ}K$   
 $R$  = gas constant  $0.0821 \text{ atm l}^{\circ}K \text{ mc}^3$   
 $M$  = molecular weight of water  $18 \text{ g}$

Substituting the expression for partial pressure in the following equation (e.g. BAVER et al. 1972, p. 305):

$$P = \frac{RT}{V_M} \ln (p/p_0) \quad (22)$$

where  $P$  = potential of soil water as pressure  
 $V_M$  = molar volume of water  $0.018 \text{ l}$   
 $p_0$  = pressure of saturated water vapor  $\text{atm}$

and multiplying by  $-1000$  we obtain the soil water potential in centimeter of water:

$$h = \frac{-1000 RT}{V_M} \ln \left( \frac{1000 c RT}{P_0 M} \right) \quad (23)$$

Figure 14 (p. 41) indicates the relation between  $\theta$  and  $h$

$$\theta = a' \log h + b = a \ln h + b \quad (24)$$

where  $a'$ ,  $a$  and  $b$  are constant

From equations (23) and (24) we get

$$\theta = a \ln \left[ \frac{-1000 RT}{V_M} \ln \left( \frac{1000 c RT}{P_0 M} \right) \right] + b \quad (25)$$

$$\frac{d\theta}{dc} = \frac{a}{2.303 \log (p/p_0) c} \quad (26)$$

From equations (20) and (26) it follows that

$$D_s = \frac{2.303 \log (p/p_0) c}{a} D_v \quad (27)$$

From Figure 14, in clay soil

$$\begin{aligned} pF &= \log h = 0.434 \ln h = -10.7 \theta + 5.99 \\ \theta &= -0.0406 \ln h + 0.560 \\ a &= -0.0406 \end{aligned}$$

The value of the coefficient  $D_v$  at 20° C is 925 cm<sup>2</sup>/h (HILLEL 1971, p. 46). The density of saturated water vapor at 20° C is 1.729 x 10<sup>-5</sup> g/cm<sup>3</sup> (WEAST 1969). For the concentration  $c$  we obtain the value

$$c = p/p_0 \times 1.729 \times 10^{-5} \text{ g/cm}^3$$

Substituting the values of  $a$ ,  $D_v$  and  $c$  into equation (27)

$$D_s = -9.07 \times 10^{-1} p/p_0 \log (p/p_0) \quad (28)$$

Table 15. Soil water diffusivity values corresponding to water vapor diffusion coefficient according to equation (28).

pF	Relative humidity $p/p_0$ according to equation (6)	$D_s$
3.0	0.9993	$2.7 \times 10^{-4}$ cm <sup>2</sup> /h
4.0	0.9927	$2.9 \times 10^{-3}$ »
5.0	0.9298	$2.7 \times 10^{-2}$ »
6.0	0.4828	$1.4 \times 10^{-1}$ »

Various values of  $D_s$  which were computed according to equation (28) are given in Table 15. Based on the results we can conclude that the drier the soil surrounding the seed, the more easily water passes into the seed in gaseous form. Immediately after planting, the soil surrounding the seed evidently dries very much. Even if the contact between seed and soil were poor, water would rapidly flow as vapor into the seed. Table 14 (p. 46) indicates that the water supply to the seed would not slow down greatly until the  $D$  value of seed and soil dropped from 10<sup>-3</sup> to 10<sup>-4</sup> cm<sup>2</sup>/h. When the water potential in the seed approaches the initial potential of the seed bed, we can conclude from the data in Tables 14 and 15 that the passage of water as a gas from soil to seed slows down greatly. At the level of moisture content where the seed will still just sprout, the passage of water as a gas into the seed is not so slow as to prevent germination, according to the calculations (Tables 14 and 15). Even if there were an abundant supply of useable water in the seed bed, it is doubtful whether poor contact would impair germination. The seed is at least partially in contact with the soil, and the soil water conductivity is considerably better in moist than in dry soil. In moist soil it is not even necessary that the seed's water intake reaches equilibrium to assure germination.

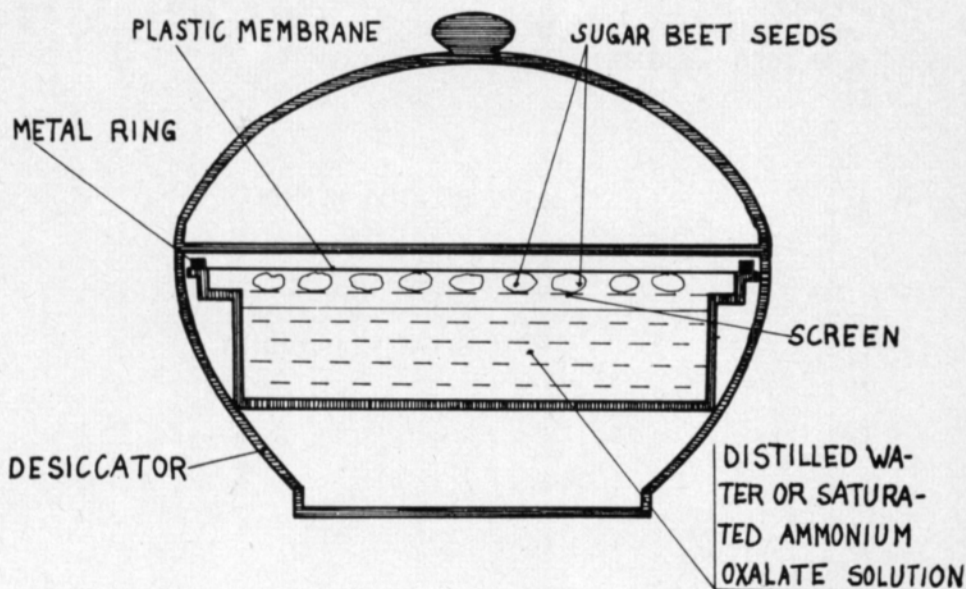

Fig. 21. Schematic diagram of equipment for the determination of water absorption as vapor by seed.

#### *b. Experimental results*

The ease with which a seed is able to obtain water in gaseous form was studied using the experimental setup in Figure 21. A screen was placed 2 mm above distilled water or saturated ammonium oxalate solution in a plastic desiccator. Seeds of the variety Monohill were placed on the screen and a plastic covering was placed over the seeds. The seeds were left on the screen from several hours to several days, after which moisture determinations were made on the seeds. The desiccator was kept within a heat insulating box in a room of constant temperature, in the manner shown in Figure 10 (p. 33). The results are shown in Figure 22. If we compare these results with the ones obtained using PEG (Figure 9, p. 30) or soil (Figure 20, p. 51) to determine the water absorption rate of seeds, we see that equilibrium was reached more slowly in the experiment outlined above. The water content of the seed rose higher at 99 % relative humidity (corresponding to a potential of  $-15$  atm) than in semi-permeable membrane tubes immersed in PEG solution at the  $-15$  atm potential. This difference may be caused by electrolytes in the fruit coat (SNYDER 1963), or because the temperature in the desiccator was not constant enough during the experiment (compare p. 33). The experiment indicates, therefore, that poor contact between seed and soil can slow down the supply of water to the seed. Equilibrium was nearly reached, however, within a couple of days. Thus the passage of water as vapor would not seem to be so slow as to lower final germination or seedling emergence. The theoretical study confirmed these results. In order to determine whether seedlings emerge as well in a coarse seed bed as in a fine one, seedling experiments were made on soils of different sized particles.

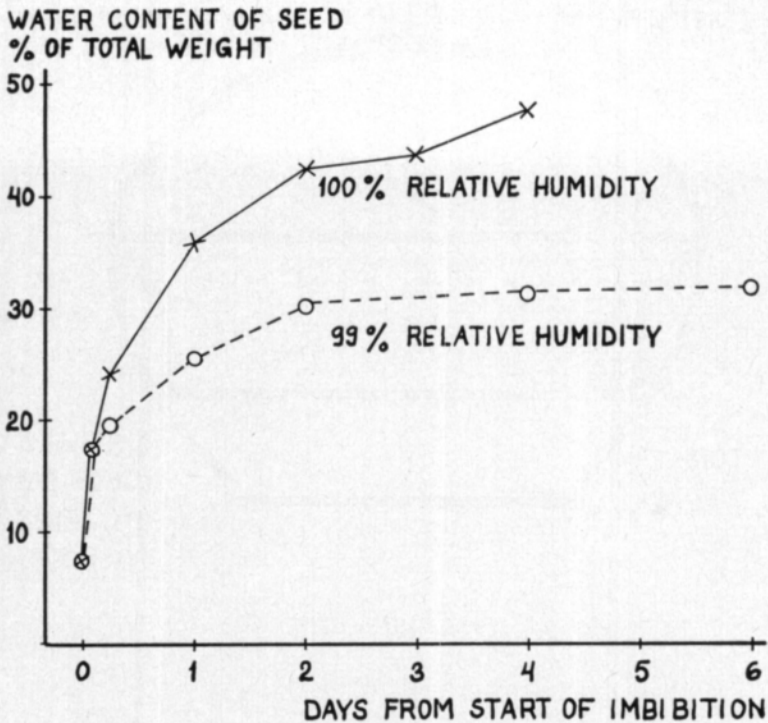

Fig. 22. Absorption of water into seed at relative humidities of 99 and 100 %.

Clay soil already brought to the desired water content (as in the study of the effects of soil water potential on seedling emergence p. 31) was sieved to separate the less than 4 mm and 4–9 mm particle size fractions. The sieves were the same as used in studying the effects of excess wetness on seedling emergence (p. 17). On both fractions, seedling experiments were made using Monohill, in the manner described on p. 31. The moisture content of these soil fractions was 19.2 % of dry matter, which corresponds to a potential of –6.4 atm using the osmotic method. A finer screening of the finer soil showed that it contained 48 % by weight of < 1 mm and 52 % by weight of 1–4 mm particles. The results of seedling counts in the experiments are shown in Table 16. The figures indicate that seedling emergence was more rapid in the finer soil

Table 16. Seedling emergence in an experiment on the effects of particle size in the seed bed. Seedlings/100 seeds.

Fraction	Days after planting				
	6	8	10	13	15
<4 mm .....	14.4	67.4	76.4	77.4	77.4
4–9 mm .....	12.4	57.2	70.2	78.0	78.0

Statistically significant difference between fractions only in counts on 8th day.



fraction than in the coarser. Eight days after planting significantly more plants had emerged in the fine soil than in the coarse. This evidently was caused by a more rapid absorption of water by the seed from the finer soil. It may also be that the sprouts were forced to go around clods in the coarse soil, and this delayed their appearance on the surface. The final results, however, showed no difference in seedling emergence between the different fractions. The result is in agreement with theoretical calculations and the results of experiments made with the desiccator.

The reason for poorer seedling emergence in coarse soil than in fine soil under practical conditions is, in most cases, that a coarser seed bed dries faster (HEINONEN 1965). In the studies of HAMMERTON (1961) on sugar beet, final seedling emergence was poorer in the 6–9 mm soil fraction than in the 3–6 mm fraction, and best in the fraction where particle size was smaller than 1 mm, although the water content of the soil was kept close to field capacity. HAMMERTON'S result is different from that of the present study. Perhaps in HAMMERTON'S studies the coarse soil offered a greater mechanical resistance, the energy of the seedlings would be used up in going around soil clods, and a greater susceptibility to diseases in the coarser soil could have accounted for the differences between the treatments.

## **7. The ability of the sugar beet seedling to overcome mechanical resistance when the soil water potential is low**

One reason why a low water content depress seedling emergence could be that the ability of the sugar beet seedling to overcome mechanical resistance decreases with decreasing availability of water. Evidently the magnitude of the turgor pressure of the cells determines how large a resistance the growing tissue is able to overcome (BARLEY and GREACEN 1967). When the soil water potential decreases, the turgor pressure of the cells also decreases and the harmful effects of mechanical resistance on growth increase. This has been shown in experiments made by GARDNER and DANIELSON (1964) on cotton roots. After initial moistening of the sugar beet seed, water intake and germination cease, according to the results presented in chapter D 2, when the water potential of the seed bed falls below  $-10$  atm. Evidently the turgor pressure in the cells of the growing sugar beet sprout is slightly above 10 atm when water is freely available. As the water potential of the seed bed decreases, so does the turgor pressure of the growing radicle and its ability to overcome mechanical resistance.

The fruit coat itself can be a great obstacle to the growth of the radicle. PETO (1964) demonstrated that by softening the fruit coat with various solutions, germination of the sugar beet is improved. Of course, the improvement may also be caused by the removal of germination inhibiting compounds from the fruit coat by the solutions (SNYDER et al. 1965).

The significance of the mechanical resistance caused by the fruit coat when the water potential is low was studied in the following experiment: A number of seeds of the variety Monohill were immersed in distilled water.

After 36 hours, the fruit coat was removed with a needle. A part of these peeled seeds was germinated in PEG at a potential of  $-13$  atm as in the earlier study on the effects of water potential on germination (p. 29). Another part of the seeds was germinated in sintered glass funnels which contained no soil, at a potential of  $-20$  cm. Within 6 days 91 radicles over 1 mm in length developed per 100 seeds in the funnels, which shows that the removal of the fruit coat had not damaged the seeds. In PEG at a potential of  $-13$  atm out of 100 seeds there were 42 radicles over 2 mm in length, while in the experiments with the unpeeled seeds, only 11 radicles developed per 100 seeds. The difference is statistically significant. The results indicate that the fruit coat is an obstacle to germination when the water potential is low. However, not one radicle grew longer than 4 mm from the peeled seeds during the 10 days period at the  $-13$  atm potential. This indicates that while peeling improves germination when the water potential is low, the extension growth of radicle is so slow that from the practical point of view of seedling emergence, the removal of the fruit coat has only slight significance.

The effects of soil water potential on seedling emergence when the soil presents a great mechanical resistance were also studied. Experiments were made on clay soil and fine sand soil. Except for compaction, the experimental setup was the same as in the study of the effects of low soil water potential on seedling emergence (p. 31). The test containers, in which the soil was compacted, were first filled to the top with soil. Then the soil was compacted with metal cylinders of a weight such as to exert a pressure on the clay soil of  $0.2$  kp/cm<sup>2</sup> and on the fine sand soil of  $0.5$  kp/cm<sup>2</sup>. Seeds of Monohill were planted after which the containers were filled with soil to slightly over the top and the soil was compacted again. In both kinds of soil the experiment was done at two levels of moisture content. The results are shown in Table 17.

Table 17. Effect of soil water potential on seedling emergence in loose and compacted soil. (Compaction: clay soil  $0.2$  kp/cm<sup>2</sup>, fine sand soil  $0.5$  kp/cm<sup>2</sup>)

	Moisture		Plants/100 seeds	
	% DM	Potential, atm	Not compacted	Compacted
Clay soil	25.1	$-1.3$	88.3 <sup>a</sup>	74.2 <sup>a</sup>
	18.0	$-9.1$	29.6 <sup>b</sup>	18.8 <sup>b</sup>
Fine sand soil	21.7	$-0.5$ (appr.)	85.4 <sup>k</sup>	36.7 <sup>lm</sup>
	9.3	$-8.9$	42.5 <sup>l</sup>	27.1 <sup>m</sup>

Means for the same soil type followed by a common letter do not differ at  $P = 0.05$ .

The results do not indicate that compaction and thus an increase in the soil's mechanical resistance is any more harmful at lower potentials than at higher ones. A weakness of the experiment was that compaction evidently affected

the mechanical resistance of moist soil in a different manner than that of dry soil. The interaction of mechanical resistance and soil water potential cannot be determined with this simple kind of experiment. In the sugar beet field, the mechanical resistance of soil near the seed results from the roller's compacting effect, or from the drying of encrusted soil. Only studies made in an experimental field will give a picture of what kind of mechanical resistance a germinating seed will, in practice, encounter. Soil compacted in the field may have characteristics quite different from soil compacted in a laboratory.

## 8. Discussion

In what ways does a low soil water content impair the germination and seedling emergence of sugar beet seeds? The theoretical calculations and experiments conducted indicate that initial moistening of the seed in soil occurs rapidly. Poor contact of the seed with the soil may, of course, slow down the primary water intake, but according to the experiments conducted poor contact with the soil would not reduce the final seedling emergence regardless of the slight delay in rising through the surface. According to theoretical studies, the low water potential of the seed bed appears to weaken greatly the ability of the plant to overcome mechanical resistance. Peeling off the

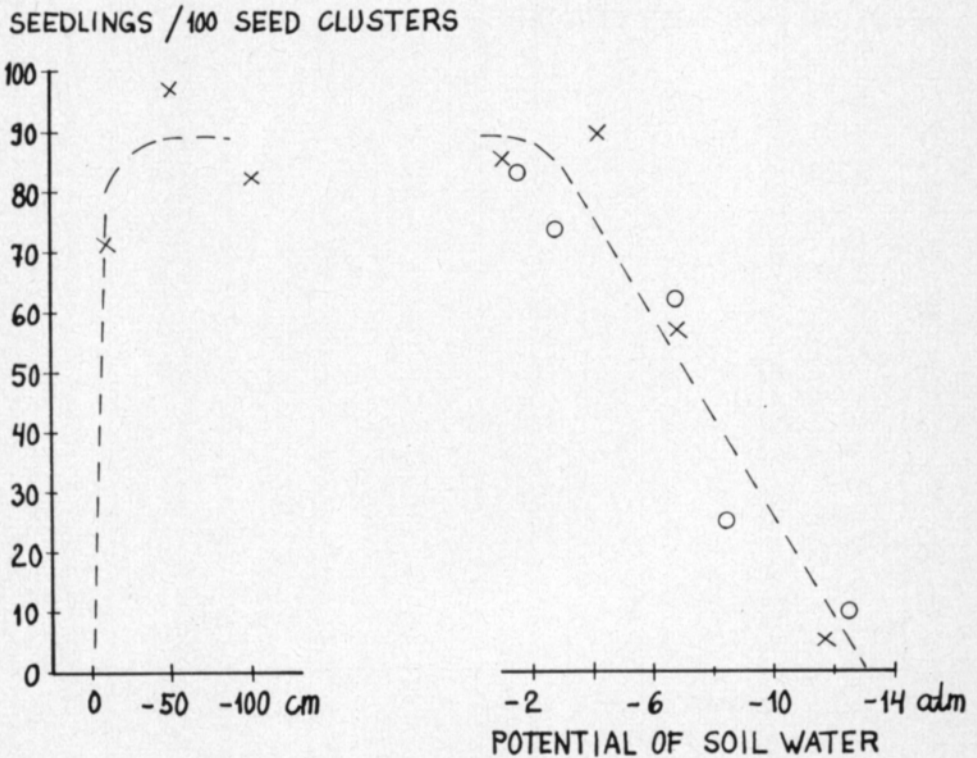

Fig. 23. Effects of the potential of soil water on the seedling emergence of the variety Monohill. Broken line drawing done freehand. x = clay soil, o = fine sand soil.

fruit coat of the sugar beet seed greatly improved germination in those experiments in which the water potential of the seed bed was low. This may be due to decreased mechanical resistance because of the peeling. Removal of the fruit coat will evidently not eliminate all the drawbacks resulting from a dry seed bed, however, since subsequent growth of the radicle at a low water potential is very slow. Evidently the impairing effect of low water content in the seed bed on seedling emergence is largely due to weakening of the growth, resulting from lowered metabolic activity in the plant, or from an inability of cells in the growth zone to increase in size, owing to lack of turgor pressure. When other factors are optimal the water potential of the seed bed evidently determines the rate of metabolism and degree of turgor pressure in the germinating sugar beet seed. The water potential of the seed bed seem to be a good indicator of the germinating sugar beet's chances of obtaining water.

The dependence of the seedling emergence of the variety Monohill on the soil water potential is shown in Figure 23. At high potentials, the results are from experiments made on particle size mixtures of clay soil. The studies carried out indicate (p. 24) that the manner in which the water potential of a wet soil affects seedling emergence is largely dependent on the structure of the soil. The results obtained with particle size mixtures have been included in the attached figure since the mixture was considered to imitate the particle distri-

### SEEDLINGS/100 SEED CLUSTERS

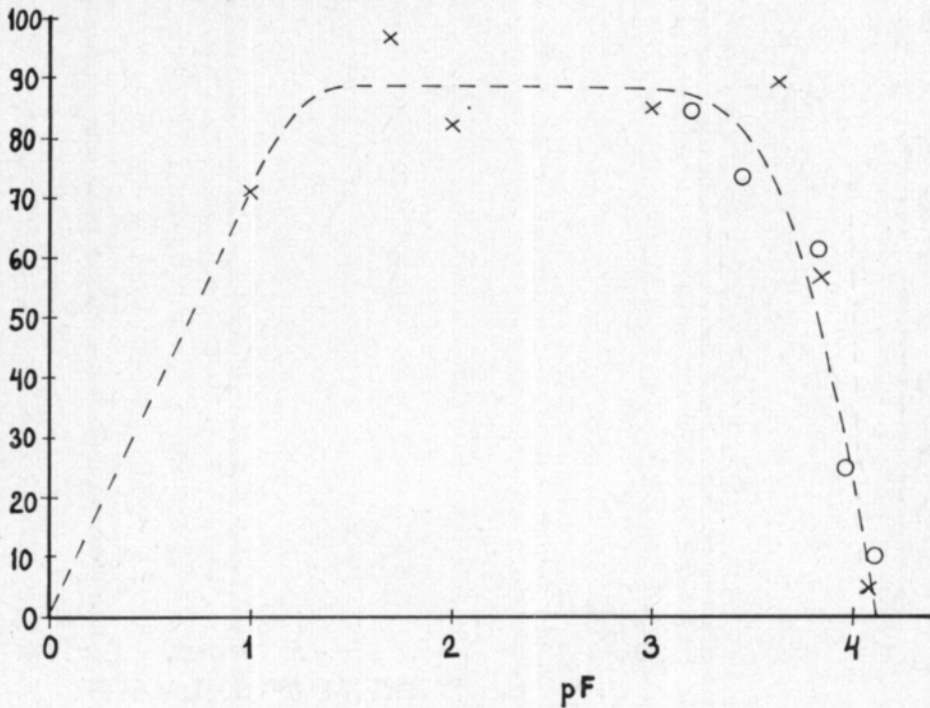

Fig. 24. Dependence of seedling emergence of the variety Monohill on soil water pF value. Approximation of curve done by hand. x = clay soil, o = fine sand soil.

bution in a successfully harrowed seed bed of clay soil. The seedling emergence results at low potentials are from fine sand and clay soil experiments. As the potential decreases below  $-4$  atm seedling emergence falls linearly, and stops completely at  $-13$  atm. Since below about  $-5$  atm a 1 % unit drop in soil water content corresponds to a drop of several atm potential (Figure 11, p.34), it is appropriate to use a pF scale to indicate the potential of soil water (Figure 24). Seedling emergence of the Monohill variety falls very sharply at pF 4 ( $= -10$  atm), so this value would be very suitable as a critical point for seedling emergence in the field.

Evidently the water potential of the unemerged sugar beet seedling is close to the soil water potential. Once the seedling has come to the surface, however, in addition to the soil water potential, the rate of transpiration through the leaves also determines the water status of the plant (HILLEL 1971, p. 203). Thus it seems more sensible to determine the soil water content that would correspond to the water potential considered critical for germination and seedling emergence than the soil water content corresponding to the wilting point for plants that have come to the surface.

The purpose of this study was to investigate the effects of water content of the soil on the germination and seedling emergence of the sugar beet seed. In this work the results on the effects of excessive wetness are very limited. Continued studies are necessary to elucidate the effects of high water potential on seedling emergence in different kinds of seed beds. According to the experiments in this study, the variety of sugar beet has very little significance in determining at how low a soil water potential a seed will germinate and a seedling emerge. Unfortunately, in the water retention curve determination for fine sand soil, different results were obtained using the osmotic method than with a pressure apparatus. The use of a moisture characteristic curve obtained by the osmotic method to determine potentials corresponding to various water contents in fine sand soil can be defended in that by so doing, the potentials of clay soil and fine sand soil had nearly the same effect on seedling emergence (Figure 12, p. 36) and rate of seedling emergence (Figure 13, p. 38). There is no reason to assume that the water potentials of the soils had a different effect on the seedling emergence of sugar beet. If a retention curve obtained by a pressure apparatus had been used for fine sand soil, the effect of potential would have been very different for fine sand soil than for clay soil. From the standpoint of consistent results, it was advantageous that at the  $-10$  atm ( $=$  pF 4) potential chosen as a critical point for seedling emergence, practically the same water content was obtained using the osmotic method as with the pressure membrane apparatus on both fine sand and clay soil.

Studies made to elucidate the effects of potential on the germination of crops other than sugar beet have produced varying results. PARMAR and MOORE (1968) experimented with the effects of water potential on the germination of maize, using filter paper soaked with PEG solution as a seed bed. Maize practically stopped germinating at a potential of  $-8$  atm. KAUFMANN (1969), who regulated the soil water potential with a semi-permeable membrane and PEG solution, demonstrated that the orange and the lettuce no longer

germinate when the soil water potential is about  $-5$  atm. However, the sunflower still germinated, though slowly, at  $-8.0$  atm. In the experiments of KAUFMANN and ROSS (1970), in which the potential was controlled as above, wheat germinated well at  $-8$  atm but not at all at  $-15$  atm. If the results obtained in the present study are compared with those obtained for other plants, we can see that the germination of sugar beet does not suffer from low water potential any more than that of other crops. This contradicts the results obtained in the studies of HUNTER and ERICKSON (1952).

In this study the experiments were carried out at a temperature of  $20^{\circ}$  C, which is the optimum for seedling emergence of sugar beet (DUBETZ et al. 1962). Field measurements made by the Research Centre indicate that temperature in the germination layer of the sugar beet field varies greatly during the spring. During warm weather, the temperature may rise above  $20^{\circ}$  C, but during cold spells it stays below  $10^{\circ}$  C. The effects of soil water potential on the seedling emergence of sugar beet may be dependent on the temperature. KAUFMANN and ROSS (1970) have demonstrated that at  $15^{\circ}$  C a low water potential has a less harmful effect on the germination of lettuce than at  $25^{\circ}$  C. With wheat, however, they did not demonstrate any interaction between temperature and potential. Even if the effects of low potential on the germination of sugar beet were dependent on temperature, we could still use the critical point of pF 4 in field experiments. If through the interaction of temperature and soil water potential the sugar beet seedling should emerge at a potential a couple atm higher or lower than in the conducted experiments, the critical point would only change by about 0.1 pF units.

## Summary

On the basis of theoretical calculations and laboratory experiments, an attempt was made to clarify the effects of both excessive wetness and inadequate moisture on the germination and seedling emergence of sugar beet.

### 1. The effects of excessive wetness on germination and seedling emergence

The experiments were made with the monogerm variety Monohill. The results of this study confirmed the view that water contained in the seed or a water film surrounding the seed is a hindrance to the adequate intake of oxygen by the seed only when the value of the water potential is very close to zero. In practice, there is scarcely any risk that excessive wetness of the seed will depress seedling emergence. The germination of pelleted seed fell due to lack of oxygen at moisture contents near saturation to a greater degree than did that of unpelleted seeds. However, at a potential of  $-30$  cm the germination of pelleted seed also was good.

The significance of excessive wetness of the soil surrounding the seed was studied using clay soil and fine sand soil. The study shows that the water potential at which the passage of oxygen into the seed is prevented depends largely on the structure of the seed bed. By measuring the air space and the relative gas diffusion coefficient at different soil water potentials on different soils, it was possible greatly to clarify the differences appearing in sugar beet seedling emergence. Experiments on clay soil indicated that as long as the soil is not encrusted seedling emergence is seldom reduced by excessive wetness of the soil. In the experiments conducted, sugar beet seedling emergence was nearly optimal even when the relative diffusion coefficient of oxygen was as low as 0.016. From experiments made on fine sand soil it appears obvious that even at soil water potentials of over  $-100$  cm, mechanical resistance can decrease sugar beet seedling emergence.

### 2. The effects of inadequate moisture on germination and seedling emergence

The effects of low water potential on germination were studied with 4 varieties: multigerm AaBeCe and Polyhill and monogerm Monohill and Mono-

beta. The sugar beet seeds were placed in cellulose acetate tubes which were immersed in polyethylene glycol solution of predetermined osmotic value. All varieties germinated well even at a potential of  $-10$  atm but at  $-13$  atm germination was slight. It appears that the different sugar beet varieties suffer in equal degree from low water potential.

To study the effects of low soil water potential on seedling emergence of sugar beet, experiments were made on clay soil and fine sand soil. The moisture characteristic curve of the experimental soils was determined osmotically using cellulose acetate membrane and PEG solution. The effects of water potential on germination appeared similar in soil to its effects in cellulose acetate tubes in polyethylene glycol solution. However, seedling emergence in soil was lower than germination in experiments with a semipermeable membrane. This was considered to result from slow extension growth of the radicle at surfacing stage owing to low water potential. A lowering of the soil water potential appeared to decrease the seedling emergence of the various test varieties almost equally. Under field conditions, a critical point of  $-10$  atm ( $=$  pF 4) was chosen, on the basis of studies made, below which seedling emergence in sugar beet does not occur. In the seedling emergence experiments made, a lowering of soil water potential not only reduced seedling emergence but also greatly slowed it down.

According to these studies, the initial water intake of the planted sugar beet seed is rapid. As early as 24 hours after planting, equilibrium in water intake has been attained. The planted seed is, according to calculations, very absorptive. The absorptive power decreases rapidly, however, as the seed becomes moist.

The water diffusivity of the seeds was determined. A number of seeds were immersed in distilled water and the moisture content of the seeds was determined at definite intervals. From the amount of water entering the seed, a coefficient or D value indicating diffusivity was calculated. The D value calculated from the amounts of water entering the seed during 2 and 6 hours was  $1.1 \times 10^{-3}$  cm<sup>2</sup>/h. The D value representing the amounts of water entering the seed during 6 and 24 hours was  $4.9 \times 10^{-4}$  cm<sup>2</sup>/h. The results are much lower than estimates generally obtained for the water diffusivity of soil. For this reason in the study of the intake of water by the seed, it was considered justifiable to ignore the resistance of the soil to the passage of water. Thus calculated values were obtained which agreed with the results of experiments made. To study experimentally the intake of water by the seed, a principle used for determining the diffusion of metals and fluids was applied to the determination of water diffusivity of experimental soil. This principle has not apparently been applied earlier in determinations of the water diffusivity of soil.

In studying the effects of poor contact between seed and soil on seedling emergence, the soil water conductivity corresponding to the water vapor diffusion coefficient was calculated. The results indicate that in very dry soil, water passes easily as vapor into the seed. In moist soil, movement of water as a gas is slow. When there is available water for plants in the soil, poor contact between soil and seed may slow down the attainment of equilibrium.



in water intake. According to calculations, this poor contact will not slow down water intake sufficiently, however, for final germination to be reduced. Results from experiments using a desiccator indicated that the passage of water as vapor by way of the air into the seed may be slower than as a liquid by way of the soil. The results indicate that the passage of water as a gas into the seed is probably not so slow that germination would be lowered. In the experiment made to study the effects of contact on seedling emergence, the sugar beet seedling came to the surface more slowly in a coarse than in a fine soil seed bed, but there was no difference in final seedling emergence between the soils studied.

A theoretical examination indicates that when the soil water potential is low, the mechanical resistance will decrease seedling emergence greatly. Removal of the fruit coat of the seed improved germination greatly in the variety Monohill when the water potential was low, but growth of the radicle was so slow that it is doubtful whether seedling emergence in dry soil can be improved by peeling the fruit coat. Experiments made on fine sand and clay soils failed to show that mechanical resistance of the soil is detrimental to seedling emergence expressly when the water potential is low.

## REFERENCES

- ALASTALO, O. 1966. Kannattaisiko kynnös tasoittaa jo syksyllä. SaSon Uutiset 8, 3: 6–8.  
 — 1968. Kevätmuokkaus erikoissiemmenten kylvöä ajatellen. SaSon Uutiset 10, 2: 2–4.
- BAKKER, J. W. HIDDING, A. P. 1970. The influence of soil structure and air content on gas diffusion in soils. Neth. J. Agric. Sci. 18: 37–48.
- BARLEY, K. P. & GREACEN, E. L. 1967. Mechanical resistance as a soil factor influencing the growth of roots and underground shoots. Adv. Agron. 19: 1–43.
- BAVER, L. D., GARDNER, W. H. & GARDNER, W. R. 1972. Soil physics. 498 p. New York.
- BLAKE, G. R. 1965. Particle density. Agronomy 9: 371–373.
- BOWER, C. A. & WILCOX, L. V. 1965. Soluble salts. Agronomy 9, 2: 933–951.
- BRUMMER, V. 1960. Sokerijuurikkaan muokkaus- ja kylvöaikakokeiden tuloksia. Maatalous 53: 246–247.  
 — 1972. Sokerijuurikas ja esikasvikysymys. SaSon Uutiset 14, 2: 2–5.
- CARSLAW, H. S. & JAEGER, J. C. 1959. Conduction of heat in solids. 510 p. Oxford.
- CHETRAM, R. S. & HEYDECKER, W. 1967. Moisture sensitivity, mechanical injury and gibberellin treatment of *Beta vulgaris* seeds. Nature 215: 210–211.
- CRANK, J. 1970. The mathematics of diffusion. 347 p. Oxford.
- CURRIE, J. A. 1960. Gaseous diffusion in porous media. Part 1. A non-steady state method. Brit. J. Appl. Phys. 11: 314–317.  
 — 1961. Gaseous diffusion in porous media. Part 3 — Wet granular materials. Brit. J. Appl. Phys. 12: 275–281.
- CZERATZKI, W. 1958. Eine keramische Platte zur serienmässigen Untersuchung von Porengrößen im Boden im Spannungsbereich bis ca –1 Atm. Z. Pflanzenern. Düng. Bodenk. 81: 50–56.
- DASBERG, S., ENOCH, H. & HILLEL, D. 1966. Effect of oxygen and carbon dioxide concentration on the germination of range grasses. Agron. J. 58: 206–208.
- DOERING, E. J. 1965. Soil-water diffusivity by the one-step method. Soil Sci. 99: 322–325.
- DUBETZ, S. 1958. The effect of fertilizers and osmotic pressure on germination. J. Amer. Soc. Sugar Beet Technol. 10: 212–219.  
 — RUSSEL, G. C. & ANDERSON, D. T. 1962. Effect of soil temperature on seedling emergence. Can. J. Plant Sci. 42: 481–487.
- DUNCAN, D. B. 1955. Multiple range and multiple F tests. Biometrics 11: 1–42.
- EIFRIG, H. 1960. Die Einkeimung in gefalteten Filterstreifen, eine neue Keimmethode für *Beta*-Arten. Saatgutwirtschaft 12: 249–251.
- ELONEN, P. 1971. Particle-size analysis of soil. Acta Agr. Fenn. 122: 1–122.
- ERICKSON, A. E. & VANDOREN, D. M. 1960. The relation of plant growth and yield to soil oxygen availability. Trans. 7th Intern. Congr. Soil Sci. III: 428–432.
- FIEDLER, J. 1970. Some aspects of sugar beet seed emergence under different moisture in the laboratory and in the field. 33rd I.I.R.B. Winter Congress 19–20/II/70 Session IV, Report 4. 6: 1–12.
- GARDNER, H. R. & DANIELSON, R. E. 1964. Penetration of wax layers by cotton roots as affected by some soil physical conditions. Soil Sci. Soc. Amer. Proc. 28: 457–460.
- GRAHAM, E. R. 1948. Determination of soil organic matter by means of a photoelectric colorimeter. Soil Sci. 65: 181–183.

- GRAY, D. E. 1972. American institute of physics handbook. 2337 p. New York.
- HAMMERTON, J. L. 1961. Studies of the effects of soil aggregate size on the emergence and growth of beet (*Beta vulgaris* L.) I. Seedling emergence. J. Agric. Sci. 56: 213–229.
- HEINONEN, R. 1965. Markens vattenhushållning och jordbearbetning. Aktuellt från Lantbruks-högskolan 69: 1–40.
- HEYDECKER, W., CHETRAM, R. S. & HEYDECKER, J. C. 1971. Water relations of beetroot seed germination. II. Effect of the ovary cap and of the endogenous inhibitors. Ann. Bot. 35: 31–42.
- & GULLIVER, R. L. 1972. Critical moisture conditions for the establishment of beet seedlings. 35th I.I.R.B. Winter Congress, 10–11/II/72 Session II, Report 2. 2: 1–11.
- HILLEL, D. 1971. Soil and water. 288 p. New York.
- HUNTER, J. R. & ERICKSON, A. E. 1952. Relation of seed germination to soil moisture tension. Agron. J. 44: 107–109.
- JACKSON, W. T. 1965. Mannitol-induced stimulation of elongation of root hairs of *Agrostis alba* L. Physiol. Plant. 18: 24–30.
- KAACK, K. & KRISTENSEN, K. J. 1967. Emergence and seedling growth related to oxygen content and oxygen diffusion rate in different soils. Agron. J. 59: 541–544.
- KAUFMANN, M. R. 1969. Effects of water potential on germination of lettuce, sunflower, and citrus seeds. Can. J. Bot. 47: 1761–1764.
- & ROSS, K. J. 1970. Water potential, temperature, and kinetin effects on seed germination in soil and solute systems. Amer. J. Bot. 57: 413–419.
- KLOOSTER, J. J. & MEIJER, E. N. C. 1972. Field emergence in relation to seedbed preparation and placement of rubbed and graded sugar beet seed. 35th I.I.R.B. Winter Congress 10–11/II/72 Session II, Report 2. 14: 1–17.
- LAKON, G. & BULAT, H. 1958. Die Feststellung der Keimfähigkeit der Rübensamen (*Beta vulgaris* L.) nach dem Topographischen Tetrazolium – Verfahren. Saatgutwirtschaft 10: 339–340.
- LAX, E. 1967. Taschenbuch für Chemiker und Physiker. Band I. 1522 p. Berlin.
- LETEY, J. & STOLZY, L. H. 1964. Measurement of oxygen diffusion rates with the platinum microelectrode I Theory and equipment. Hilgardia 35: 545–554.
- LINDELÖF, E. 1932. Differentiaali- ja integraalilasku ja sen sovellutukset. II Kahden tai useamman muuttujan funktiot. 408 p. Helsinki.
- LONGDEN, P. C. 1972. Effects of some soil conditions on sugar-beet seedling emergence. J. Agric. Sci. Camb. 79: 543–545.
- MAYER, A. M. & POLJAKOFF-MAYBER, A. 1963. The germination of seeds. 236 p. Oxford.
- MÜLLER, H. J. 1972. Beziehungen zwischen der Aggregatverteilung des Bodens im Saatbett und der Anzahl an Gesamtpflanzen nach dem Aufgang der Zuckerrüben. 35. Winterkongress des I.I.R.B. vom 10–11/II/72 Sektion II, Beitrag 2. 8: 1–7.
- NEEB, O. 1969. Zur Interpretation von Feldaufgangs-Unterschieden in Aufgangsprüfungen mit Zuckerrübensaatgut. I.I.R.B. 4: 11–21.
- & WINNER, C. 1968. Zur Problematik des Zuckerrübenanbaues ohne Vereinzlung. Zucker 21: 445–450.
- OEHME, H. 1969. Der Aufgang von Zuckerrüben auf dem Feld in Abhängigkeit von Saatgut, Standort, Saatzeit und Aussaatverfahren. Albrecht-Thaer-Archiv 13: 671–686.
- OHMURA, T. & HOWELL, R. W. 1960. Inhibitory effect of water on oxygen consumption. Plant Physiology 35: 184–188.
- PARMAR, M. T. & MOORE, R. P. 1968. Carbowax 6 000, mannitol, and sodium chloride for simulating drought conditions in germination studies of corn (*Zea mays* L.) of strong and weak vigor. Agron. J. 60: 192–195.
- PENMAN, H. L. 1940. Gas and vapour movements in the soil. I the diffusion of vapours through porous solids. J. Agric. Sci. 30: 437–462.
- PETO, F. H. 1960. Methods of loosening tight seed caps in monogerm seed to improve germination. J. Amer. Soc. Sugar Beet Technol. 13: 281–285.
- PHILLIPS, R. E. 1968. Water diffusivity of germinating soybean, corn, and cotton seed. Agron. J. 60: 568–571.
- RYTI, R. 1965. On the determination of soil pH. J. Scient. Agric. Soc. Finland 37: 51–60.

- SNYDER, F. W. 1963. Some physico-chemical factors of the fruit influencing speed of germination of sugar beet seed. *J. Amer. Soc. Sugar Beet Technol.* 12: 371—377.
- SEBESON, J. M. & FAIRLEY, J. L. 1965. Relation of water soluble substances in fruits of sugar beet to speed of germination of sugar beet seeds. *J. Amer. Soc. Sugar Beet Technol.* 13: 379—388.
- THIELEBEIN, M. 1960. Voraussetzungen für den Feldaufgang von Rübensaatgut. *Zucker* 13: 539—545.
- WALDRON, L. J. & MANBEIAN, T. 1970. Soil moisture characteristics by osmosis with polyethylene glycol: a simple system with osmotic pressure data and some results. *Soil Sci.* 110: 401—404.
- WEAST, R. C. 1969. *Handbook of chemistry and physics.* 2356 p. Cleveland.
- WENGEL, R. W. 1966. Emergence of corn in relation to soil oxygen diffusion rates. *Agron. J.* 58: 69—72.
- The West-European Working Group on Soil Structure of the Intern. Soil Sci. Soc. 1967. *West-European methods for soil structure determination* 538 p. Ghent.
- WIGGANS, S. C. & GARDNER, F. P. 1959. Effectiveness of various solutions for simulating drought conditions as measured by germination and seedling growth. *Agron. J.* 51: 315—318.
- WILLIAMS, J. & SHAYKEWICH, C. F. 1969. An evaluation of polyethylene glycol (P.E.G.) 6 000 and P.E.G. 20 000 in the osmotic control of soil water matric potential. *Can. J. Soil Sci.* 49: 397—401.

## Selostus

### Maan kosteuden vaikutus sokerijuurikkaan itämiseen ja taimistumiseen

ERKKI AURA

*Yliopiston maanviljelyskemian laitos, Helsinki*

Teoreettisilla laskelmilla ja laboratoriokokein on pyritty selvittämään toisaalta maan liiallisen kosteuden, toisaalta maan liian vähäisen kosteuden vaikutusta sokerijuurikkaan siemenen itämiseen ja taimistumiseen.

#### *1. Liiallisen kosteuden vaikutukset*

Kokeet tehtiin yksi-ituisella Monohill-lajikkeella. Tutkimus vahvisti käsitystä, että siemenessä oleva vesi tai siementä ympäröivä vesikalvo on esteenä siemenen riittävälle hapen saannille ainoastaan silloin, kun veden potentiaalinen arvo on aivan lähellä nollaa. Käytännössä tuskin on vaarana, että siemenen liiallinen kosteus häiritسی taimistumista. Pilleröidyn siemenen itävyys kärsi lähellä kyllästyskosteutta hapen puutteesta suuremmassa määrin kuin pilleröimättömän siemenen. Kuitenkin jo  $-30$  cm:n potentiaalissa oli pilleröidynkin siemenen itävyys hyvä.

Siementä ympäröivän maan liiallisen kosteuden merkitystä selvitettiin savimaan ja hienohietamaan avulla. Tehdyn tutkimuksen mukaan kylvöalustan rakenteesta riippuu hyvin paljon, kuinka korkeassa maaveden potentiaalissa vesi alkaa haitata hapen kulkeutumista siemenen. Mittaamalla eri maille ilmatila ja suhteellinen kaasun diffuusiokerroin eri maaveden potentiaaleissa voitiin suuressa määrin selittää juurikkaan taimistumisessa esiintyviä eroja. Savimaan kokeet osoittivat, että jos kylvöalusta ei ole liettynt, niin taimistuminen kärsinee harvoin maan liiallisen kosteuden vuoksi. Suoritetuissa kokeissa oli juurikkaan taimistuminen lähes optimaalista, vaikka suhteellisella diffuusiokertoimella oli niinkin alhainen arvo kuin 0.016. Hietamaalla tehtyjen kokeiden mukaan näyttää ilmeiseltä, että jopa yli  $-100$  cm:n maaveden potentiaalissa mekaaninen vastus voi haitata sokerijuurikkaan taimistumista.

#### *2. Liian pienen kosteuden vaikutukset*

Alhaisen veden potentiaalisen vaikutusta itämiseen tutkittiin neljällä lajikkeella: moni-ituisilla AaBeCe:llä ja Polyhillillä sekä yksi-ituisilla Monohillillä ja Monobetalla. Juurikkaan siemenet sijoitettiin selluloosa-asettaattiputkiin, jotka upotettiin polyetylen glykoliliuokseen, jolla oli tietty osmoottinen arvo. Kaikki lajikkeet itivät hyvin vielä  $-10$  atm:n potentiaalissa, mutta  $-13$  atm:n potentiaalissa itäminen oli vähäistä. Näyttää siltä, että eri sokerijuurikkalajikkeiden itäminen kärsii samalla tavoin pienestä veden potentiaalista.

Tutkittaessa alhaisen maaveden potentiaalisen vaikutusta sokerijuurikkaan taimistumiseen tehtiin kokeet savimaalla ja hienohietamaalla. Koemaiden vedenpidätyskäyrä määritettiin osmoottisesti selluloosa-asettaattikalvoa ja PEG-liuosta käyttäen. Maaveden potentiaalilla näytti olevan suunnilleen sama vaikutus itävyyteen kuin veden potentiaalilla selluloosa-ase-

taattiputkissa polyetylenyglykoliliuoksessa. Sen sijaan taimistuminen maassa oli vähäisempää kuin itäminen puoliläpäisevällä kalvolla tehdyissä kokeissa. Tämän katsottiin johtuvan hi-taasta idun pituuskasvusta maassa pintaantulovaiheessa pienen veden potentiaalin vuoksi. Maaveden potentiaalinen pieneminen näytti vähentävän lähes yhtä voimakkaasti koelajik-keiden taimistumista. Kenttäolosuhteista varten raja-arvoksi, jonka alapuolella sokerijuurikas ei enää juuri taimistu, valittiin suoritettujen tarkastelujen perusteella  $-10 \text{ atm}$  ( $= pF 4$ ). Tehdyissä taimistumiskokeissa maaveden potentiaalinen pieneminen ei ainoastaan vähentänyt taimistu-mista, vaan myös hidasti sitä suuresti.

Suoritettujen tutkimusten mukaan maahan kylvetyn sokerijuurikkaan siemenen primääri-vedenotto on nopeata. Jo vuorokauden kuluttua kylvämisestä on tasapaino veden otossa lähes saavutettu. Maahan kylvetty siemen on suoritettujen laskelmien mukaisesti hyvin imu-kykyinen. Imukyky pienenee kuitenkin nopeasti, kun siemen kostuu.

Siemenelle määritettiin vedenjohtokyky. Tällöin joukko siemeniä upotettiin tislattuun veteen ja siemenistä määritettiin kosteus tietyin aikaväleihin. Siemeniin menneestä veden määrästä laskettiin johtokykyä osoittavan kertoimen  $D$  arvo. Kahden ja kuuden tunnin aikana siemeniin menneestä veden määrästä lasketun  $D:n$  arvo oli  $1.1 \times 10^{-3} \text{ cm}^2/\text{h}$ . Kuuden tunnin ja vuorokauden aikana siemeniin kulkeutuneen veden määrästä lasketun  $D:n$  arvo oli  $4.9 \times 10^{-4} \text{ cm}^2/\text{h}$ . Tulokset ovat paljon pienempiä, kuin mitä yleensä maalle on saatu veden-johtokyvyksi. Tästä syystä katsottiin siemenen veden saantia koskevassa tarkastelussa voi-tavan jättää maan aiheuttama vastus veden liikkumiselle kokonaan huomioonottamatta. Näin suoritettulla teoreettisella tarkastelulla saatiin kokeellisten arvojen kanssa yhtäpitäviä tuloksia. Selvitettäessä kokeellisesti siemenen veden ottoa koemaalle määritettiin vedenjohto-kyky periaatteella, joka on käytössä tutkittaessa metallien ja nesteiden diffuusiota. Periaatetta ei ehkä ole aikaisemmin sovellettu vedenjohtokyvyn määrittämiseen maalle.

Selvitettäessä siemenen ja maan välisen kontaktin vaikutusta taimistumiseen laskettiin, millaista maan vedenjohtokykyä vesihöyryn diffuusiokerroin vastaa. Tulokseksi saatiin, että hyvin kuivassa maassa vesi kulkeutuu helposti kaasuna siemeneen. Kosteassa maassa veden liikkuminen kaasuna on hidasta. Kun maassa on kasveille käyttökelpoista vettä, huono kontakti maan ja siemenen välillä voi hidastaa tasapainon saavuttamista veden otossa. Las-kelmien mukaan ei tällöin huono kontakti hidasta veden saantia kuitenkaan niin paljon, että lopullinen itäminen vähenisi. Eksikaattorin avulla tehty koe osoitti, että veden kulkeutuminen siemeneen höyrynä ilman kautta voi olla hitaampaa kuin nesteinä maan kautta. Kokeen mu-kaan veden kulkeutuminen kaasuna siemeneen ei ole kuitenkaan niin hidasta, että itäminen juuri huononisi. Kontaktin vaikutusta taimistumiseen selvittävässä kokeessa sokerijuurikas nousi hitaammin pintaan karkeassa kuin hienossa kylvöalustassa, mutta lopullisessa taimistu-misessa ei tutkittujen maiden välillä ollut eroa.

Teoreettisen tarkastelun mukaisesti maaveden potentiaalinen ollessa alhainen mekaaninen vastus haittaa suuresti taimistumista. Monohill-lajikkeella pähkylän kuoriminen paransi paljon itämistä, kun veden potentiaali oli pieni, mutta idun kasvu oli niin hidasta, että kuori-misella tuskin voidaan taimistumista kuivassa maassa parantaa. Hieta- ja savimaalla tehtyjen kokeiden avulla ei voitu osoittaa, että maan mekaaninen vastus olisi haitallista taimistumiselle nimenomaan veden potentiaalinen ollessa alhainen.